



DESCRIPTION

- Two stage
- 240 volts
- Single speed
- 5.7 "/145 mm diameter
- Double ball bearings
- Tangential bypass discharge
- Aluminum fan end bracket
- Aluminum commutator bracket

DESIGN APPLICATION

- Equipment operating in environments requiring separation of working air from motor ventilating air.
- Designed to handle clean, dry, filtered air only.

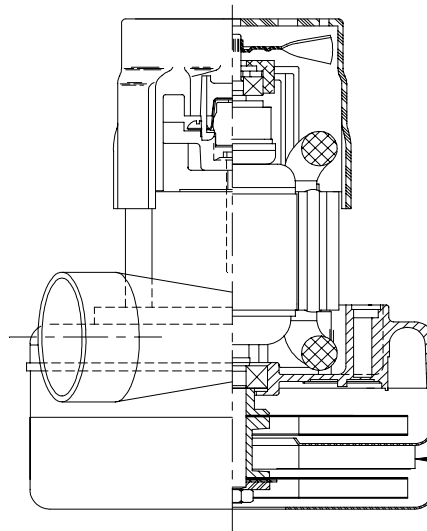

SPECIAL FEATURES

- Suitable for 240 volt AC operation, 50/60 Hz.
- UL recognized, category PRGY2 (E47185)
- 10 mm shaft and bearing system
- Provision for grounding.
- Skeleton-frame design
- "Air Sea;" Bearing protection and epoxy paint.
- Aluminum fan end bracket designed to dampen vibration and improve durability.
- With Reverse Direction Flow Cooling fan
- The Lamb Electric vacuum motor line offers a wide range of performance levels to meet design needs

TYPICAL MOTOR PERFORMANCE.*

(At 240 volts, 60Hz, test data is corrected to standard conditions of 29.92 Hg, 68° F.)

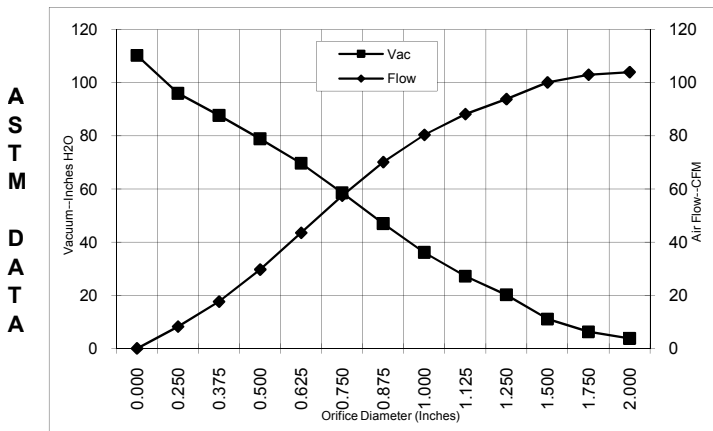

Orifice (Inches)	Amps	Watts (In)	RPM	Vac (In.H ₂ O)	Flow (CFM)	Air Watts
2.000	6.3	1400	21100	3.8	104.0	46
1.750	6.3	1400	21180	6.3	103.0	77
1.500	6.3	1400	21140	11.1	100.1	131
1.250	6.3	1410	21190	20.2	93.8	223
1.125	6.3	1410	21200	27.2	88.2	282
1.000	6.3	1400	21310	36.2	80.4	342
0.875	6.2	1370	21520	47.0	70.1	387
0.750	5.9	1330	21940	58.6	57.5	396
0.625	5.6	1250	22610	69.7	43.5	356
0.500	5.2	1150	23520	78.9	29.7	275
0.375	4.7	1060	24540	87.7	17.6	181
0.250	4.3	970	25820	96.0	8.2	92
0.000	3.9	890	26660	110.3	0.0	0

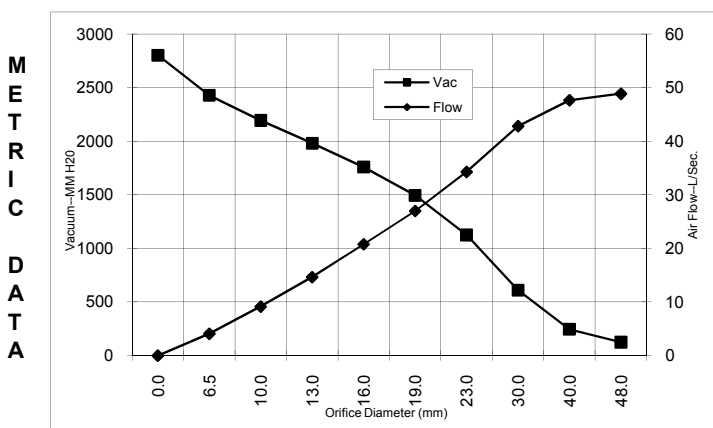

Orifice (mm)	Amps	Watts (In)	RPM	Vac (mm H ₂ O)	Flow (L/Sec)	Air Watts
48.0	6.3	1400	21135	124	48.9	60
40.0	6.3	1400	21152	245	47.7	115
30.0	6.3	1410	21196	611	42.8	255
23.0	6.2	1378	21468	1125	34.3	376
19.0	5.9	1328	21953	1494	27.0	395
16.0	5.6	1253	22583	1759	20.8	358
13.0	5.2	1160	23429	1981	14.7	283
10.0	4.8	1074	24387	2194	9.2	195
6.5	4.3	975	25756	2428	4.1	96
0.0	3.9	890	26660	2802	0.0	0

Note: Metric performance data is calculated from the ASTM data above.

* Data represents performance of a typical motor sampled from a large production quantity. Individual motor data may vary due to normal manufacturing variations.

Test Specs:	240 volts	Minimum Sealed Vacuum:	105.0"	ORIFICE:	13mm	Minimum Vacuum:	66.0"	Maximum Watts:	1450
--------------------	------------------	-------------------------------	---------------	-----------------	-------------	------------------------	--------------	-----------------------	-------------

DIMENSIONS

NOTES:

1. LEADS: 18 GA. STRANDED, LEADS CAN BE ANY COLOR EXCEPT GREEN OR GREEN WITH YELLOW STRIPE.
2. GROUNDING OR EARTHING PROVISIONS: USE HOLES AS INDICATED FOR GROUNDING OR EARTHING. REFER TO APPROPRIATE LISTING OR REGULATORY AGENCY FOR PROPER METHOD OF GROUNDING OR EARTHING.

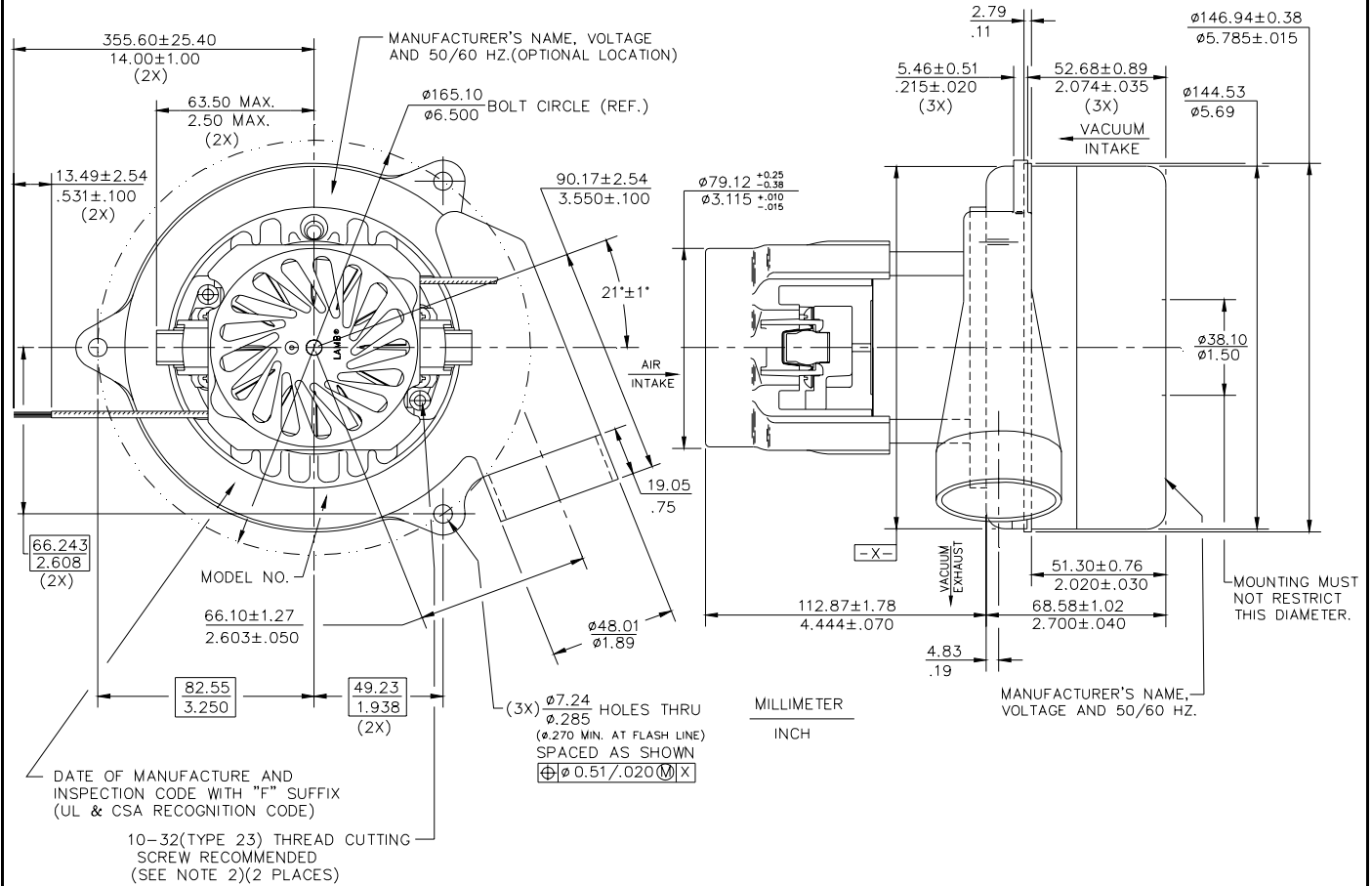

IMPORTANT NOTE: Pictorial and dimensional data are subject to change without notice. Contact factory for current revision levels.

WARNING - When using AMETEK Lamb Electric bypass motors in machines that come in contact with foam, liquid (including water), or other foreign substances, the machine must be designed and constructed to prevent those substances from reaching the fan system, motor housing, and electrical components. Lamb Electric vacuum motors other than hazardous duty models should not be applied in machines that come in contact with dry chemicals or other volatile materials. Failure to observe these precautions could cause flashing (depending on volatility) or electrical shock which could result in property damage and severe bodily injury, including death in extreme cases. All applications incorporating Lamb Electric motors should be submitted to appropriate organizations or agencies for testing specifically related to the safety of your equipment.

AMETEK/Lamb Electric Division
627 Lake Street
Kent, Ohio 44240
U.S.A.
Tel: (330) 673-3451 Fax: (330) 673-8994
www.lambelectric.com