

## LAMB ELECTRIC

**Model: 117525-00**

### DESCRIPTION

- Two stage
- 230 volts
- 7.2"/183 mm diameter
- Double ball bearings
- Single speed
- Tangential bypass discharge
- Thermoset fan end bracket
- Thermoset commutator bracket

### DESIGN APPLICATION

- Equipment operating in environments requiring separation of working air from motor ventilating air
- Designed to handle clean, dry, filtered air only

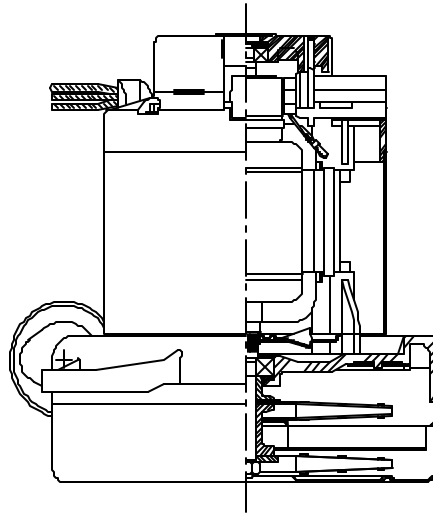

### SPECIAL FEATURES

- Suitable for 230 volt AC operation, 50/60 Hz
- UL recognized, category PRGY2 (E47185)
- Provision for grounding
- 10 mm shaft and bearing system
- The Lamb Electric vacuum motor line offers a wide range of performance levels to meet design needs

### TYPICAL MOTOR PERFORMANCE.\*

(At 230 volts, 60Hz, test data is corrected to standard conditions of 29.92 Hg, 68° F.)

ASTM DATA

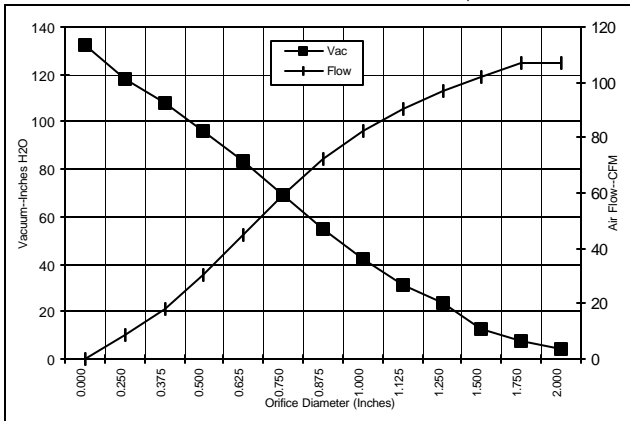

Orifice (Inches)	Amps	Watts (In)	RPM	Vac (In.H <sub>2</sub> O)	Flow (CFM)	Air Watts
2.000	6.8	1454	17330	4.2	107.0	53
1.750	6.8	1458	17293	7.2	107.0	91
1.500	6.8	1458	17280	12.4	101.7	149
1.250	6.9	1461	17260	23.3	96.6	265
1.125	6.9	1462	17270	31.4	90.5	334
1.000	6.8	1455	17283	41.9	82.3	406
0.875	6.8	1443	17393	54.9	72.0	434
0.750	6.6	1407	17643	69.1	59.1	480
0.625	6.2	1334	18173	83.1	44.9	438
0.500	5.8	1225	18646	95.9	30.7	346
0.375	5.2	1135	19883	107.6	18.3	231
0.250	4.8	1044	20940	118.0	8.8	122
0.000	4.4	961	21913	132.4	0.0	0

METRIC DATA

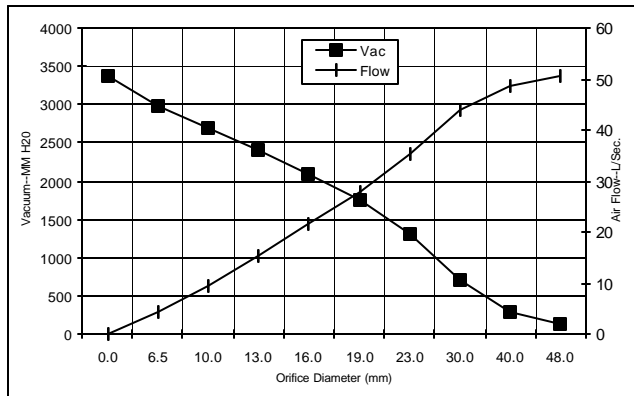

Orifice (mm)	Amps	Watts (In)	RPM	Vac (mm H <sub>2</sub> O)	Flow (L/Sec)	Air Watts
48.0	6.8	1456	17314	140	50.5	70
40.0	6.8	1458	17284	275	48.8	132
30.0	6.9	1462	17266	705	44.0	303
23.0	6.8	1446	17366	1312	35.2	427
19.0	6.6	1406	17654	1762	27.8	479
16.0	6.2	1337	18152	2097	21.5	440
13.0	5.8	1236	18599	2403	15.2	355
10.0	5.3	1149	19697	2688	9.5	248
6.5	4.8	1049	20887	2984	4.4	127
0.0	4.4	961	21913	3363	0.0	0

Note: Metric performance data is calculated from the ASTM data above.

\* Data represents performance of a typical motor sampled from a large production quantity. Individual motor data may vary due to normal manufacturing variations.

Test Specs:	230 volts	Minimum Sealed Vacuum:	107.0"	ORIFICE:	7/8"	Minimum Vacuum:	42.0"	Maximum Watts:	1460
-------------	-----------	------------------------	--------	----------	------	-----------------	-------	----------------	------

**DIMENSIONS**

**NOTES:**

1. LEADS: 18GA. STRANDED, ONE BLACK AND ONE WHITE, GROUND LEAD: 18GA. STRANDED; COLOR GREEN WITH YELLOW STRIPE.

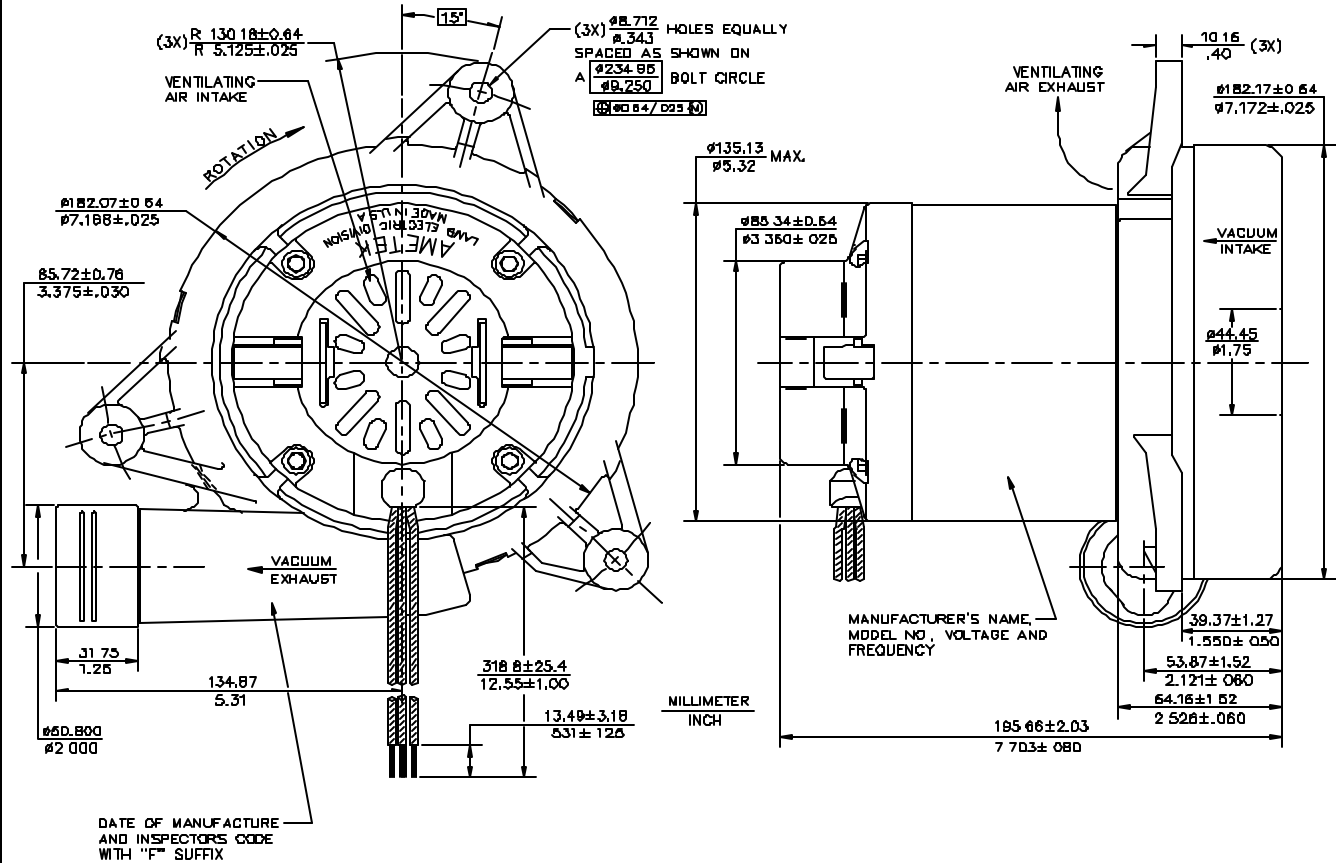

**IMPORTANT NOTE:** Pictorial and dimensional data are subject to change without notice. Contact factory for current revision levels.

**WARNING** - When using AMETEK Lamb Electric bypass motors in machines that come in contact with foam, liquid (including water), or other foreign substances, the machine must be designed and constructed to prevent those substances from reaching the fan system, motor housing, and electrical components. Lamb Electric vacuum motors other than hazardous duty models should not be applied in machines that come in contact with dry chemicals or other volatile materials. Failure to observe these precautions could cause flashing (depending on volatility) or electrical shock which could result in property damage and severe bodily injury, including death in extreme cases. All applications incorporating Lamb Electric motors should be submitted to appropriate organizations or agencies for testing specifically related to the safety of your equipment.

**AMETEK/Lamb Electric Division**  
 627 Lake Street  
 Kent, Ohio 44240  
 U.S.A.  
 Tel: (330) 673-3451  
 Fax: (330) 673-8994

**Ametek GmbH**  
 Weillimdorfer Str. 47  
 D-70825 Korntal-Munchingen  
 Germany  
 Phone: + 49-711-838-7876  
 Fax: + 49-711-838-7862

**AMETEK/Singapore Private Limited**  
 10 Ang Mo Kio Street 65  
 # 05-12 Techpoint  
 Singapore 2056  
 Tel: + 65-484-2388  
 Fax: + 65-481-6588