



SPECIAL FEATURES

- Suitable for 240 volt AC operation, 50/ 60 Hz
- UL recognized, category PRGY2 (E47185)
- CSA Certified, class 1611 01 (LR31393)
- Provision for grounding
- Open frame design
- 10mm shaft and bearing system
- Aluminum fan end bracket designed to dampen vibration and improve durability
- The Lamb Electric vacuum motor line offers a wide range of performance levels to meet design needs
- *-29 features patented air seal bearing protection, (U.S. #4,088,424) plus epoxy paint, and a 1.5" inlet tube**

DESCRIPTION

- Three stage
- 240 volts
- 5.7"/145 mm diameter
- Double ball bearings
- Single speed
- Tangential bypass discharge
- Aluminum fan end bracket
- Aluminum commutator bracket

DESIGN APPLICATION

- Equipment operating in environments requiring separation of working air from motor ventilating air
- Designed to handle clean, dry, filtered air only

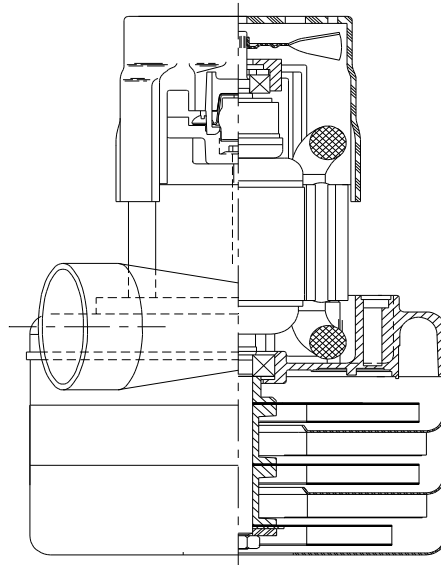

TYPICAL MOTOR PERFORMANCE.*

(At 240 volts, 60Hz, test data is corrected to standard conditions of 29.92 Hg, 68° F.)

**A
S
T
M

D
A
T
A**

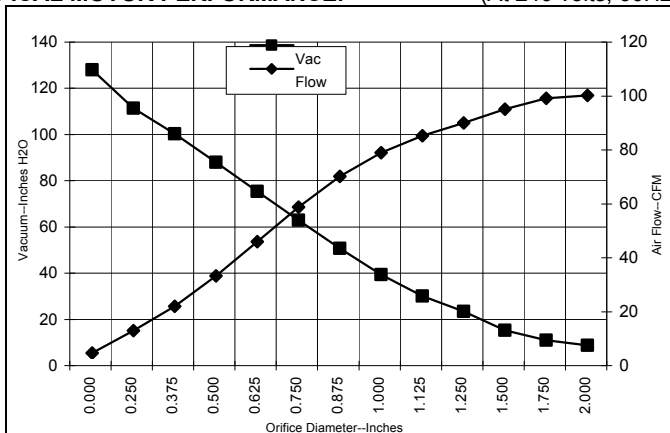

Orifice (Inches)	Amps	Watts (In)	RPM	Vac (In.H ₂ O)	Flow (CFM)	Air Watts
2.000	5.4	1208	18073	3.3	95.5	37
1.750	5.4	1205	18053	5.6	94.5	62
1.500	5.4	1207	18016	9.8	90.5	104
1.250	5.4	1214	17943	18.0	85.4	181
1.125	5.5	1225	17893	24.6	80.6	233
1.000	5.5	1233	17840	33.9	74.3	296
0.875	5.5	1233	17890	45.3	65.5	348
0.750	5.4	1212	18066	57.5	54.1	366
0.625	5.1	1152	18566	70.0	41.3	339
0.500	4.7	1076	19320	82.5	28.6	277
0.375	4.3	984	20320	94.9	17.3	193
0.250	3.9	897	21360	106.0	8.3	105
0.000	3.5	821	22453	122.5	0.0	0

**M
E
T
R
I
C

D
A
T
A**

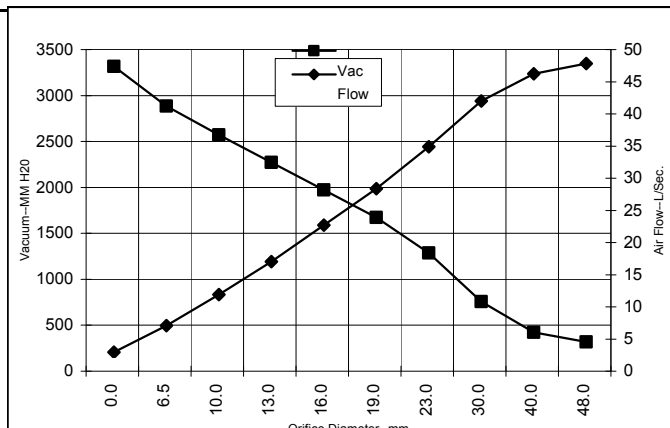

Orifice (mm)	Amps	Watts (In)	RPM	Vac (mm H ₂ O)	Flow (L/Sec)	Air Watts
48.0	5.4	1207	18064	110	44.9	48
40.0	5.4	1206	18027	217	43.3	91
30.0	5.4	1220	17916	549	39.1	210
23.0	5.5	1233	17878	1078	32.0	335
19.0	5.4	1211	18076	1467	25.4	365
16.0	5.1	1154	18546	1765	19.7	340
13.0	4.8	1084	19245	2064	14.1	283
10.0	4.4	998	20170	2363	9.0	206
6.5	3.9	901	21308	2678	4.1	109
0.0	3.5	821	22453	3112	0.0	0

Note: Metric performance data is calculated from the ASTM data above.

* Data represents performance of a typical motor sampled from a large production quantity. Individual motor data may vary due to normal manufacturing variations.

Test Specs:	240 volts	Minimum Sealed Vacuum:	112.0"	ORIFICE:	7/8 "	Minimum Vacuum:	44.0"	Maximum Watts:	1450
--------------------	------------------	-------------------------------	---------------	-----------------	--------------	------------------------	--------------	-----------------------	-------------

DIMENSIONS

NOTES:

- LEADS: 18 GA. STRANDED. LEADS CAN BE ANY COLOR EXCEPT GREEN OR GREEN WITH YELLOW STRIPE.
- GROUNDING OR EARTHING PROVISIONS: USE HOLES AS INDICATED FOR GROUNDING OR EARTHING. REFER TO APPROPRIATE LISTING OR REGULATORY AGENCY FOR PROPER METHOD OF GROUNDING OR EARTHING.

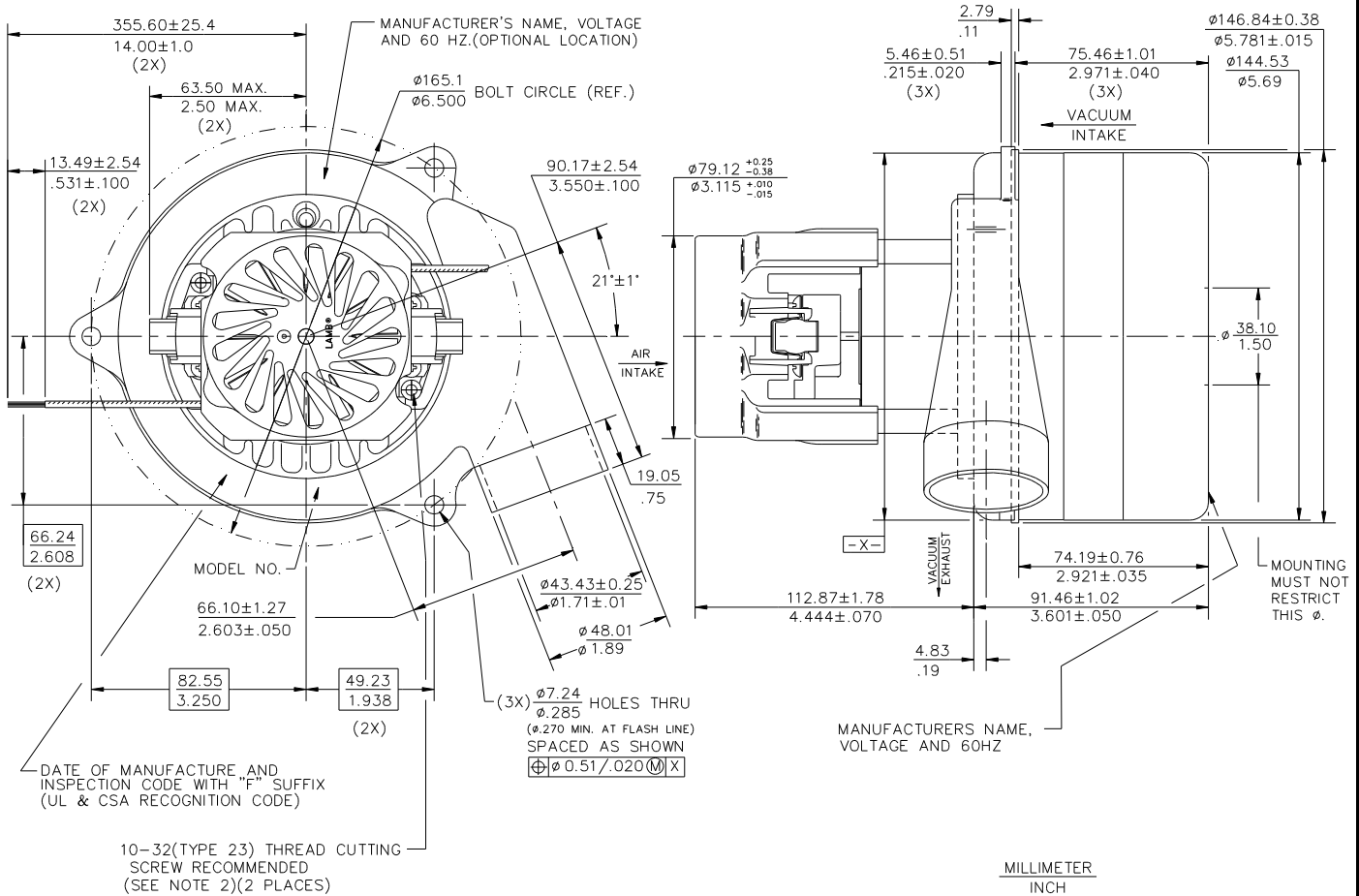

IMPORTANT NOTE: Pictorial and dimensional data are subject to change without notice. Contact factory for current revision levels.

WARNING - When using AMETEK Lamb Electric bypass motors in machines that come in contact with foam, liquid (including water), or other foreign substances, the machine must be designed and constructed to prevent those substances from reaching the fan system, motor housing, and electrical components. Lamb Electric vacuum motors other than hazardous duty models should not be applied in machines that come in contact with dry chemicals or other volatile materials. Failure to observe these precautions could cause flashing (depending on volatility) or electrical shock which could result in property damage and severe bodily injury, including death in extreme cases. All applications incorporating Lamb Electric motors should be submitted to appropriate organizations or agencies for testing specifically related to the safety of your equipment.

AMETEK/Lamb Electric Division
 627 Lake Street
 Kent, Ohio 44240
 U.S.A.
 Tel: (330) 673-3451
 Fax: (330) 673-8994

Ametek GmbH
 P. O. Box 1251
 D-71667 Marbach
 Germany
 Phone: + 49-714-484-9512
 Fax: + 49-714-484-9513

AMETEK/Singapore Private Limited
 10 Ang Mo Kio Street 65
 # 05-12 Techpoint
 Singapore 2056
 Tel: + 65-484-2388
 Fax: + 65-481-6588