



FLO-TEK

DESCRIPTION

- One stage
- 24 volts
- 9.0" / 229 mm diameter
- Dual ball bearings
- Tangential discharge
- All aluminum die cast housings used in motor construction

DESIGN APPLICATION

- Equipment operating in environment requiring separation of working air from motor ventilating air
- Designed to handle clean, dry, filtered air only

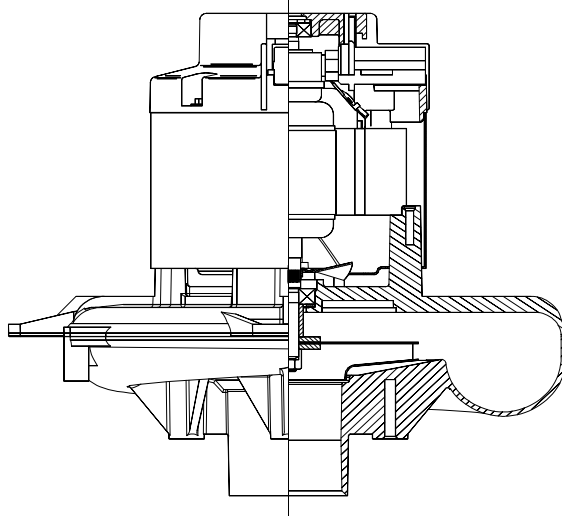

SPECIAL FEATURES

- Suitable for 24v AC operation, 50/60 Hz
- UL component recognized
- Provision for grounding
- 10 mm shaft and bearing system
- Flat fan system
- Aluminum fan end bracket designed to dampen vibration and improve durability
- The Lamb vacuum motor line offers a wide range of performance levels to meet design needs

TYPICAL MOTOR PERFORMANCE.*

(At 24 volts, 60Hz, test data is corrected to standard conditions of 29.92 Hg, 68° F.)

ASTM DATA

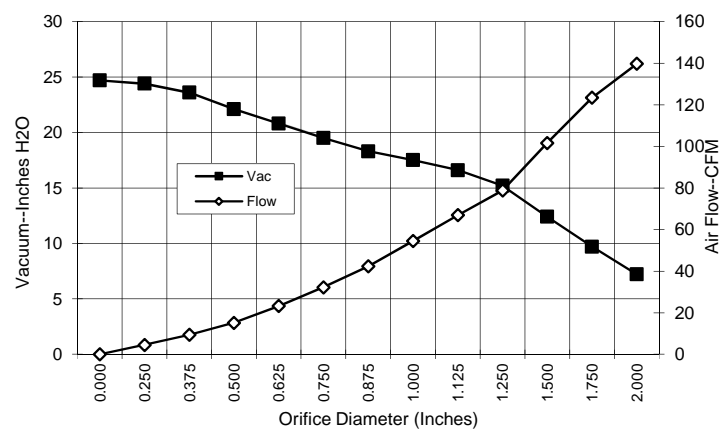

| Orifice (Inches) | Amps | Watts (In) | RPM | Vac (In.H2O) | Flow (CFM) | Air Watts |
|------------------|------|------------|-------|--------------|------------|-----------|
| 2.000 | 18.3 | 438 | 12165 | 7.2 | 139.7 | 119 |
| 1.750 | 18.2 | 437 | 12160 | 9.7 | 123.4 | 141 |
| 1.500 | 17.8 | 427 | 12335 | 12.4 | 101.6 | 148 |
| 1.250 | 17.2 | 413 | 12670 | 15.2 | 78.8 | 141 |
| 1.125 | 16.8 | 404 | 12935 | 16.6 | 66.9 | 131 |
| 1.000 | 16.3 | 392 | 13265 | 17.5 | 54.4 | 112 |
| 0.875 | 15.8 | 380 | 13655 | 18.3 | 42.3 | 91 |
| 0.750 | 15.3 | 368 | 14055 | 19.5 | 32.2 | 74 |
| 0.625 | 14.8 | 356 | 14475 | 20.8 | 23.2 | 57 |
| 0.500 | 14.4 | 345 | 14880 | 22.1 | 15.1 | 39 |
| 0.375 | 13.9 | 335 | 15360 | 23.6 | 9.3 | 26 |
| 0.250 | 13.6 | 327 | 15640 | 24.4 | 4.5 | 13 |
| 0.000 | 13.4 | 321 | 15840 | 24.7 | 0.0 | 0 |

METRIC DATA

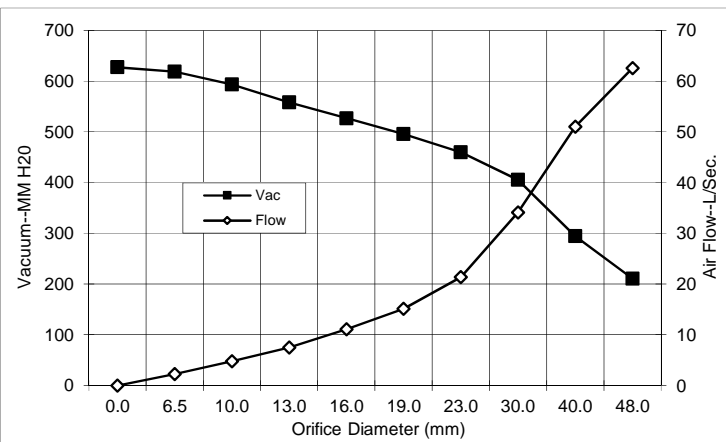

| Orifice (mm) | Amps | Watts (In) | RPM | Vac (mm H2O) | Flow (L/Sec) | Air Watts |
|--------------|------|------------|-------|--------------|--------------|-----------|
| 48.0 | 18.2 | 438 | 12163 | 211 | 62.6 | 129 |
| 40.0 | 17.9 | 430 | 12283 | 294 | 51.0 | 146 |
| 30.0 | 17.0 | 408 | 12816 | 406 | 34.1 | 136 |
| 23.0 | 16.0 | 383 | 13558 | 460 | 21.4 | 96 |
| 19.0 | 15.3 | 368 | 14063 | 496 | 15.1 | 74 |
| 16.0 | 14.8 | 356 | 14458 | 527 | 11.1 | 58 |
| 13.0 | 14.4 | 346 | 14840 | 558 | 7.5 | 41 |
| 10.0 | 14.0 | 337 | 15288 | 594 | 4.8 | 28 |
| 6.5 | 13.6 | 327 | 15626 | 619 | 2.2 | 14 |
| 0.0 | 13.4 | 321 | 15840 | 627 | 0.0 | 0 |

Note: Metric performance data is calculated from the ASTM data above.

* Data represents performance of a typical motor sampled from a large production quantity. Individual motor data may vary due to normal manufacturing variances.

| | | | | | | | |
|----------------|-----|---------------------------|-------|---------------|-------------------|-----|--------------------|
| Test Specs: TI | 24V | Minimum Sealed Vacuum: TB | 19.5" | ORIFICE: 7/8" | Minimum Vacuum: 1 | 16" | Maximum Watts: 440 |
|----------------|-----|---------------------------|-------|---------------|-------------------|-----|--------------------|



DIMENSIONS

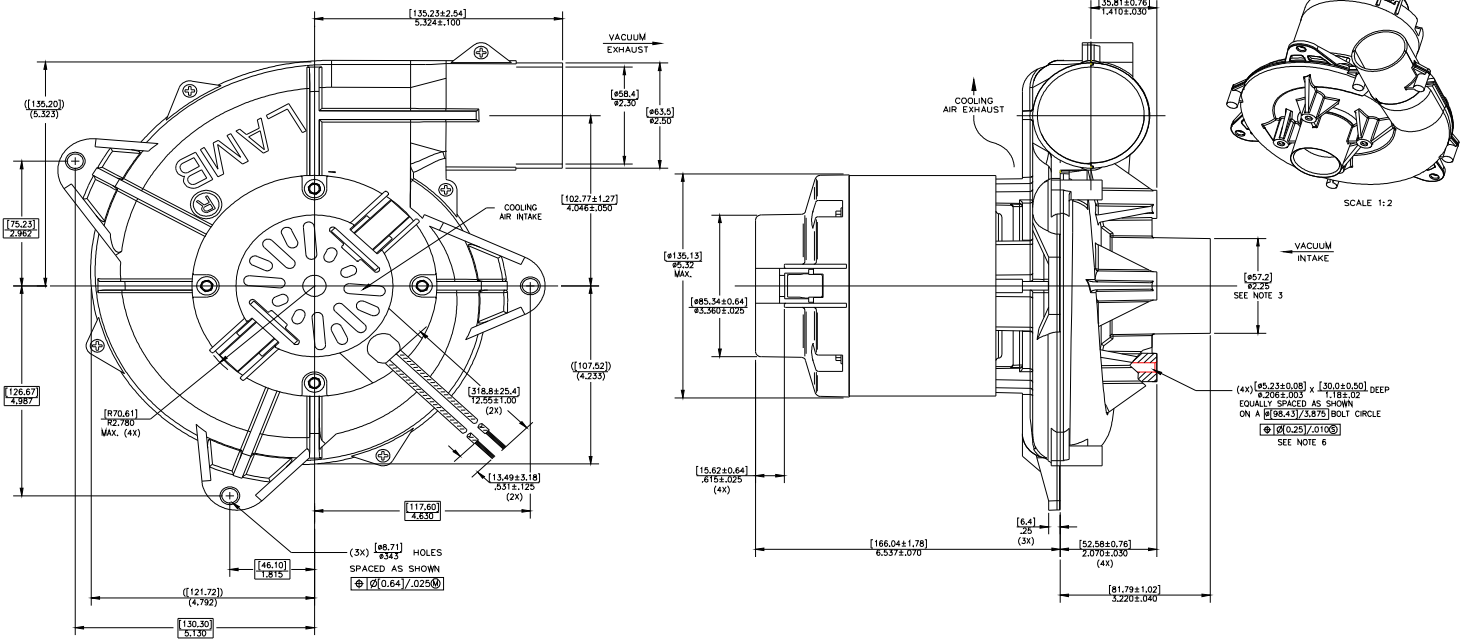

NOTES:

1. LEADS: 16 GA. STRANDED; POWER LEADS ONE BLACK AND ONE WHITE.
2. MOTOR IDENTIFICATION: MANUFACTURER'S NAME, MODEL NUMBER, VOLTAGE, FREQUENCY, INSPECTORS CODE, DATE OF MANUFACTURE, AGENCY RECOGNITION CODE, PLANT LOCATION CODE AND COUNTRY OF ORIGIN.
3. MOUNTING MUST NOT RESTRICT THIS DIAMETER.
4. COOLING AIR INTAKE MUST BE SEPARATED FROM COOLING AIR EXHAUST.
5. COOLING AIR EXHAUST MUST BE SEPARATED FROM VACUUM EXHAUST.
6. RECOMMENDED SCREW SIZE 1/4-20 TYPE BT OR TYPE 25 THREAD CUTTING SCREW. MINIMUM PENETRATION [20.32]/.800.

Manufactured under Patent nos. US5789893, TW81993, SG38957, ZA96/2766, US5760519, EP0702448B1, ZA95/7123 under license from Switched Reluctance Drives Ltd. Other US and foreign patents pending. Copyright code 1998. All rights reserved.

IMPORTANT NOTES: Pictorial and dimensional data are subject to change without notice. Contact factory for current revision levels.

WARNING - When using AMETEK/Lamb Electric bypass motors in machines that come in contact with foam, liquid (including water) of other foreign substances, the machine must be designed and constructed to prevent those substances from reaching the fan system, motor housing and electrical components. Lamb vacuum motors other than hazardous duty models should not be applied in machines that come in contact with dry chemicals or other volatile materials. Failure to observe these precautions could cause flashing (depending on volatility) or electrical shock which could result in property damage and severe bodily injury, including death in extreme cases. All applications incorporating Lamb motors should be submitted to appropriate organizations or agencies for testing specifically related to the safety of your equipment.

AMETEK/Floorcare & Specialty Motors
www.ametekfsm.com