

Low Voltage Brushless DC Blowers

3.0 (76mm) BLDC Low-Voltage Blower

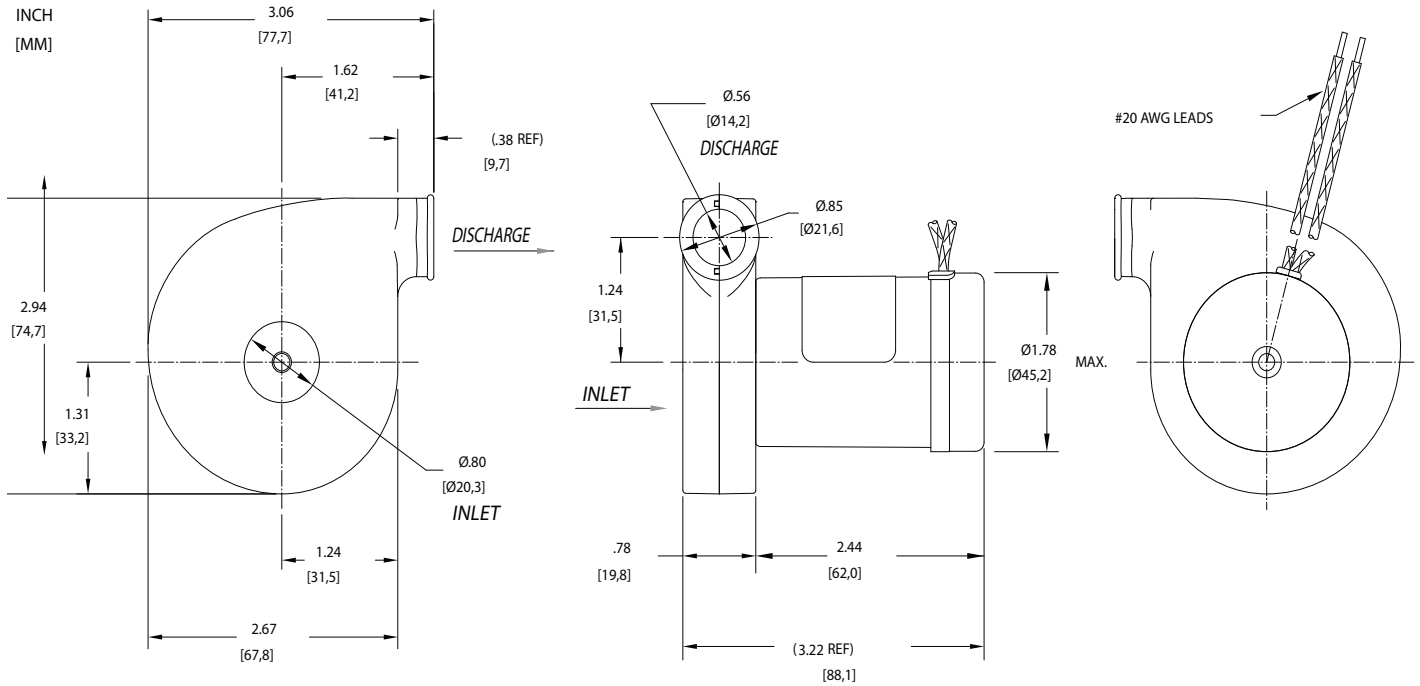

12/24 VDC Input, High Output



Specification	Units	Part/ Model Number	
		150908	150918
Voltage	VDC	16-28	5-14
Stages	-	1	1
Max Sealed Pressure	in. H2O	24.9	24.9
	mbar	62	62
Max Open Flow Rate	CFM	24.6	24.6
	m3/hr	41.8	41.8

Notes:

- **Temperature:** Working Air: 0°C to 45°C, Ambient Air: 0°C to 45°C, Storage: -40°C to 85°C.
- Customized performance available upon request. Please contact AMETEK Technical & Industrial Products' Marketing and Sales Department.
- When used as a vacuum, the blower performance might be less than shown herein, depending on the operating point.
- Please observe proper polarity for power connections. Improper connections will damage the blower's electronics.
- **Optional** - Motor configuration available with connection to external controller.
- **Optional** - 2-Wire Operation: The 3.0, 3.3, 4.5 inch Windjammers operate with a simple two-wire configuration. The blower speed is directly proportional to the supply voltage, and there is no separate speed command signal input or speed setting via potentiometer. The supply voltage powers both the motor winding and the motor controller. Operating points below the minimum supply voltage stated in the chart above can be achieved by providing a third wire to power the motor controller separately from the motor winding. This feature is available upon request.
- **Weight** = 9 oz / .3 Kg
- **Optional Tachometer Output:** A square wave output whose signal is 2x the blower rotational frequency.

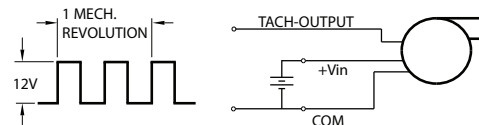

This document is for informational purposes only and should not be considered as a binding description of the products or their performance in all applications. The performance data on this page depicts typical performance under controlled laboratory conditions. AMETEK is not responsible for blowers driven beyond factory specified speed, temperature, pressure, flow or without proper alignment. Actual performance will vary depending on the operating environment and application. AMETEK products are not designed for and should not be used in medical life support applications. AMETEK reserves the right to revise its products without notification. The above characteristics represent standard products. For product designed to meet specific applications, contact AMETEK Dynamic Fluid Solutions Sales department.



Typical Performance

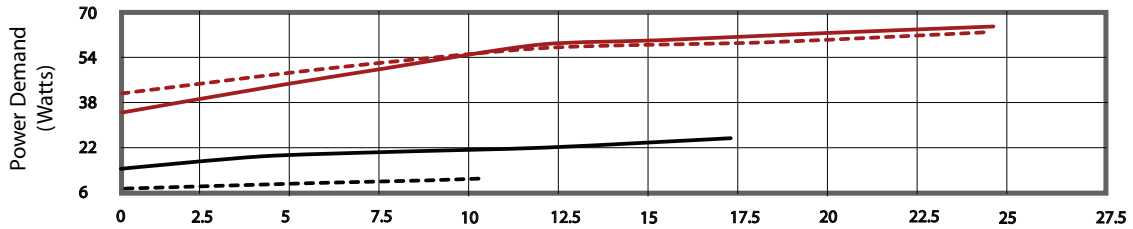
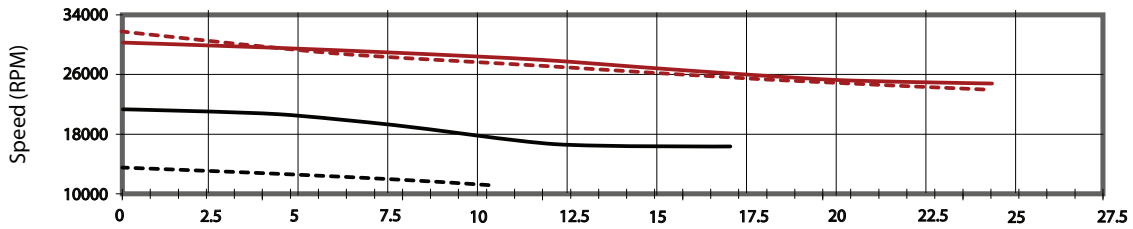
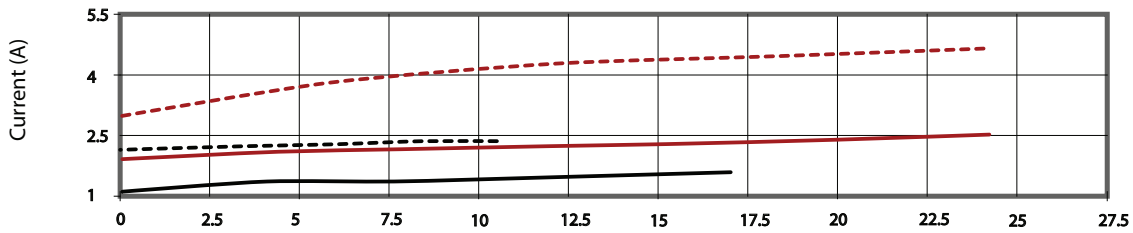
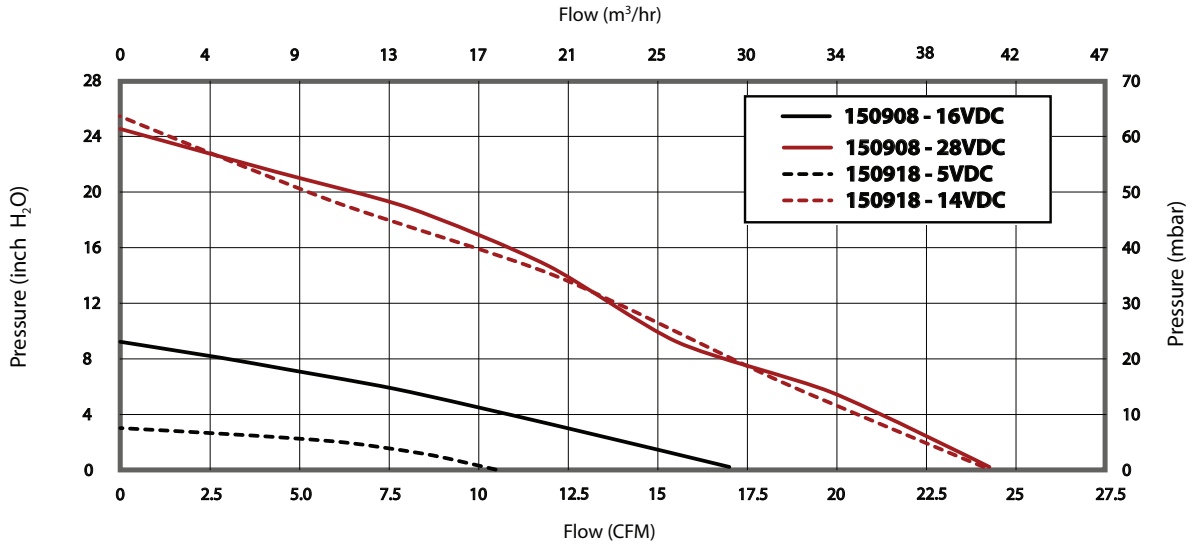

Data presented represents blower performance at STANDARD AIR DENSITY, .075 lb/ft³ (29.92" Hg, Sea Level, 68° F)
 Vacuum performance available upon request.

This document is for informational purposes only and should not be considered as a binding description of the products or their performance in all applications. The performance data on this page depicts typical performance under controlled laboratory conditions. AMETEK is not responsible for blowers driven beyond factory specified speed, temperature, pressure, flow or without proper alignment. Actual performance will vary depending on the operating environment and application. AMETEK products are not designed for and should not be used in medical life support applications. AMETEK reserves the right to revise its products without notification. The above characteristics represent standard products. For product designed to meet specific applications, contact AMETEK Dynamic Fluid Solutions Sales department.

Low Voltage Brushless DC Blowers

3.0" (76mm) BLDC Low-Voltage Blower



12/24 VDC

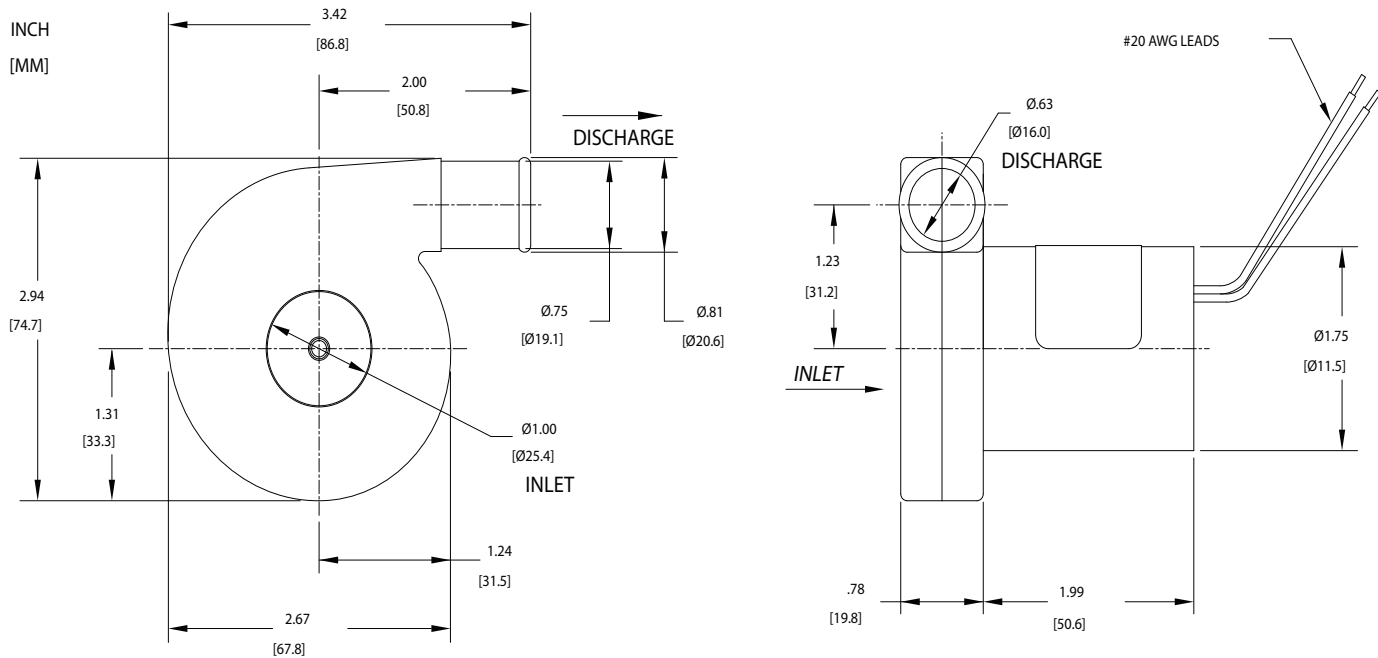

Specification	Units	Part/ Model Number	
		119349	119350
Voltage	VDC	6-14	16-28
Stages	-	1	1
Max Sealed Pressure	in. H ₂ O	13.4	14.0
	mbar	33.4	34.9
Max Open Flow Rate	CFM	19.8	20.6
	m ³ /hr	33.7	35

Notes:

- **Temperature:** Working Air: 0°C to 45°C, Ambient Air: 0°C to 45°C, Storage: -40°C to 85°C.
- Customized performance available upon request. Please contact AMETEK Technical & Industrial Products' Marketing and Sales Department.
- When used as a vacuum, the blower performance might be less than shown herein, depending on the operating point.
- Please observe proper polarity for power connections. Improper connections will damage the blower's electronics.
- **Optional** - Motor configuration available with connection to external controller.
- **Optional** - 2-Wire Operation: The 3.0, 3.3, 4.5 inch Windjammers operate with a simple two-wire configuration. The blower speed is directly proportional to the supply voltage, and there is no separate speed command signal input or speed setting via potentiometer. The supply voltage powers both the motor winding and the motor controller. Operating points below the minimum supply voltage stated in the chart above can be achieved by providing a third wire to power the motor controller separately from the motor winding. This feature is available upon request.
- **Weight** = 9 oz. / .3 Kg

Optional Tachometer Output: A square wave output whose signal is 2x the blower rotational frequency

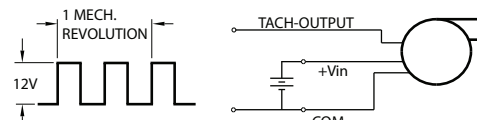

This document is for informational purposes only and should not be considered as a binding description of the products or their performance in all applications. The performance data on this page depicts typical performance under controlled laboratory conditions. AMETEK is not responsible for blowers driven beyond factory specified speed, temperature, pressure, flow or without proper alignment. Actual performance will vary depending on the operating environment and application. AMETEK products are not designed for and should not be used in medical life support applications. AMETEK reserves the right to revise its products without notification. The above characteristics represent standard products. For product designed to meet specific applications, contact AMETEK Dynamic Fluid Solutions Sales department.



Typical Performance

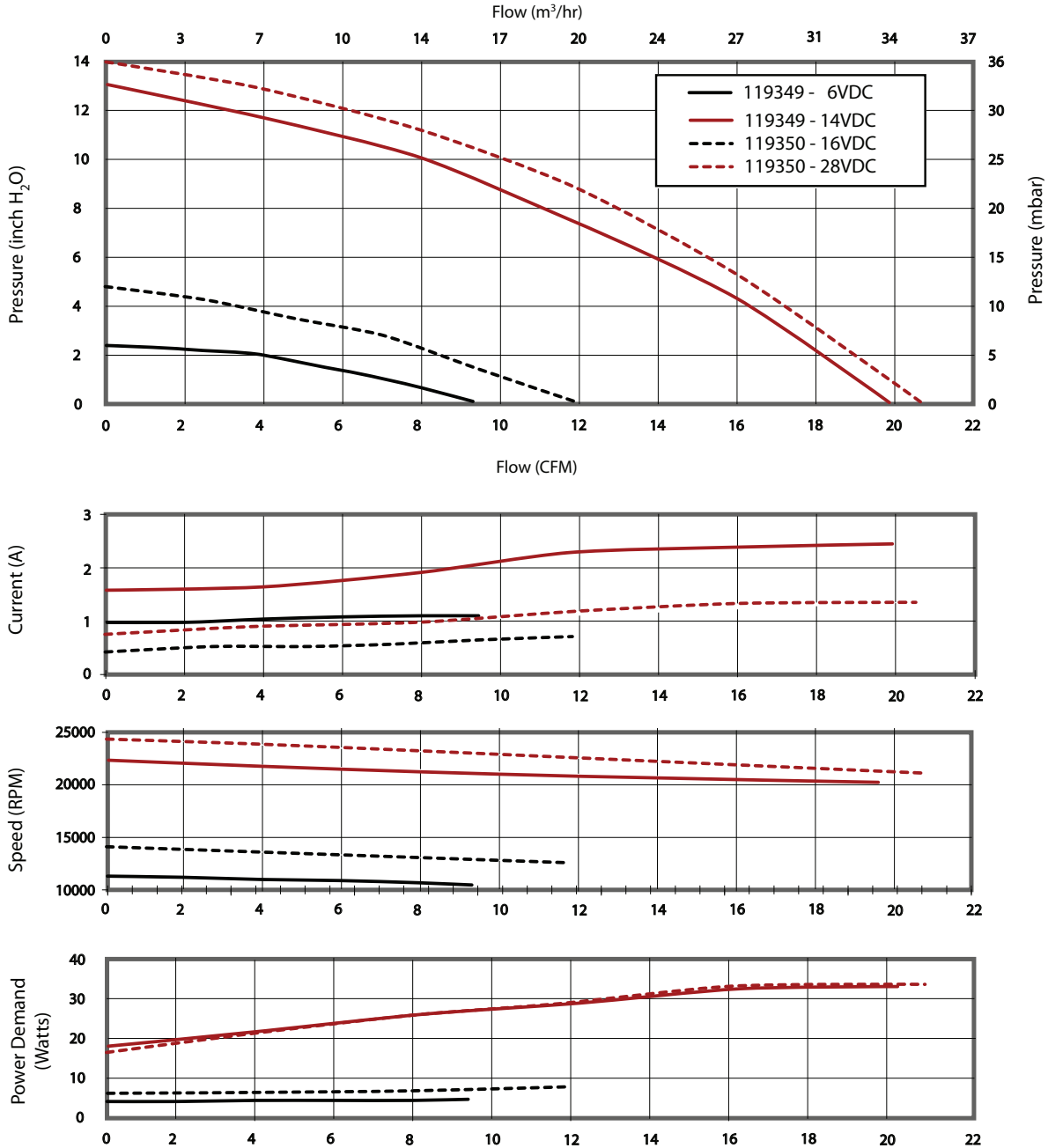

Data presented represents blower performance at STANDARD AIR DENSITY, .075 lb/ft³ (29.92" Hg, Sea Level, 68° F)
 Vacuum performance available upon request.

This document is for informational purposes only and should not be considered as a binding description of the products or their performance in all applications. The performance data on this page depicts typical performance under controlled laboratory conditions. AMETEK is not responsible for blowers driven beyond factory specified speed, temperature, pressure, flow or without proper alignment. Actual performance will vary depending on the operating environment and application. AMETEK products are not designed for and should not be used in medical life support applications. AMETEK reserves the right to revise its products without notification. The above characteristics represent standard products. For product designed to meet specific applications, contact AMETEK Dynamic Fluid Solutions Sales department.

Low Voltage Brushless DC Blowers

3.3" (84mm) BLDC Low-Voltage Blower



12/24 VDC

INCH
[MM]

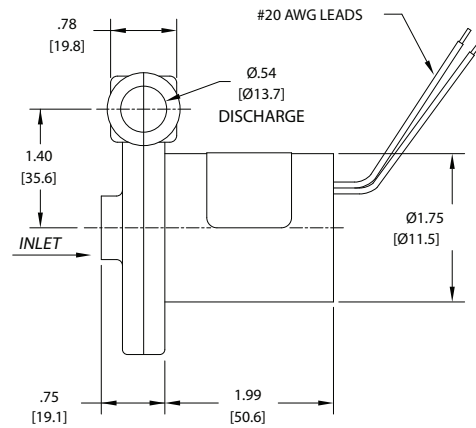
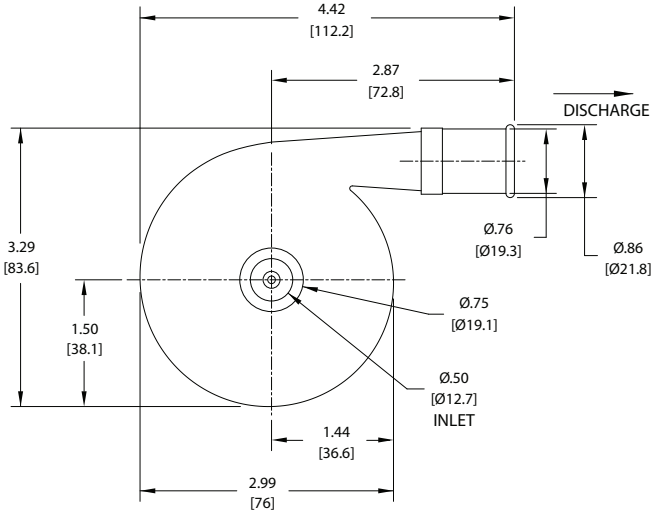

Specification	Units	Part/ Model Number	
		119497	119498
Voltage	VDC	6-13	16-26
Stages	-	1	1
Max Sealed Pressure	in. H2O	26.0	26.0
	mbar	64.8	64.8
Max Open Flow Rate	CFM	6.6	7.1
	m3/hr	11.2	12.1

Notes:

- **Temperature:** Working Air: 0°C to 45°C , Ambient Air: 0°C to 45°C, Storage: -40°C to 85°C.
- Customized performance available upon request. Please contact AMETEK Technical & Industrial Products' Marketing and Sales Department.
- When used as a vacuum, the blower performance might be less than shown herein, depending on the operating point.
- Please observe proper polarity for power connections. Improper connections will damage the blower's electronics.
- **Optional** - Motor configuration available with connection to external controller.
- **Optional** - 2-Wire Operation: The 3.0, 3.3, 4.5 inch Windjammers operate with a simple two-wire configuration. The blower speed is directly proportional to the supply voltage, and there is no separate speed command signal input or speed setting via potentiometer. The supply voltage powers both the motor winding and the motor controller. Operating points below the minimum supply voltage stated in the chart above can be achieved by providing a third wire to power the motor controller separately from the motor winding. This feature is available upon request.
- **Weight** = 9 oz / .3 Kg
- **Optional Tachometer Output:** A square wave output whose signal is 2x the blower rotational frequency.

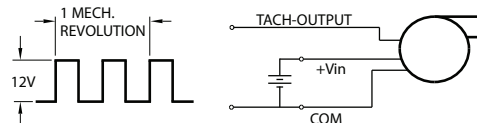

This document is for informational purposes only and should not be considered as a binding description of the products or their performance in all applications. The performance data on this page depicts typical performance under controlled laboratory conditions. AMETEK is not responsible for blowers driven beyond factory specified speed, temperature, pressure, flow or without proper alignment. Actual performance will vary depending on the operating environment and application. AMETEK products are not designed for and should not be used in medical life support applications. AMETEK reserves the right to revise its products without notification. The above characteristics represent standard products. For product designed to meet specific applications, contact AMETEK Dynamic Fluid Solutions Sales department.

Typical Performance

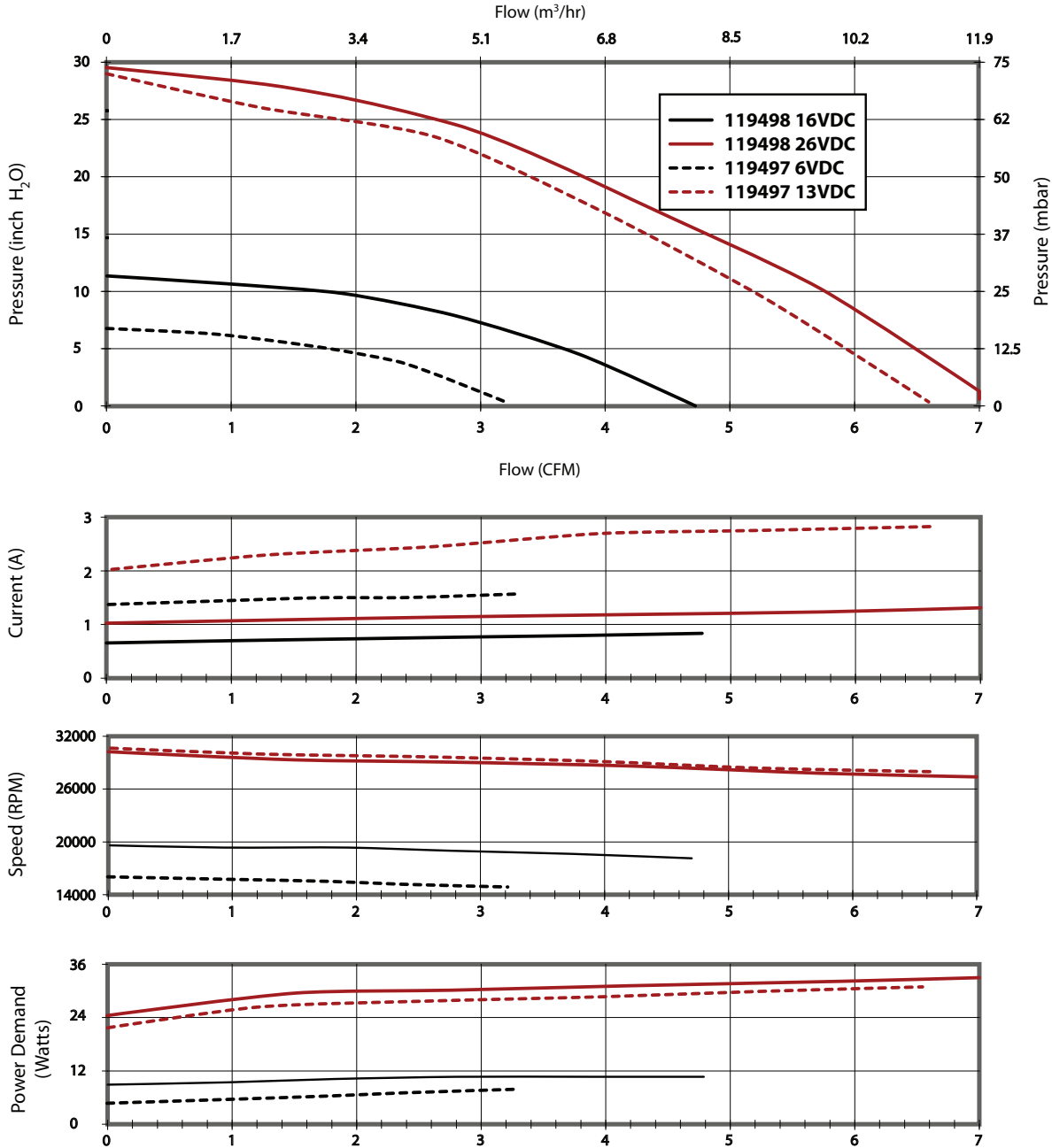

Data presented represents blower performance at STANDARD AIR DENSITY, .075 lb/ft³ (29.92" Hg, Sea Level, 68° F) Vacuum performance available upon request.

This document is for informational purposes only and should not be considered as a binding description of the products or their performance in all applications. The performance data on this page depicts typical performance under controlled laboratory conditions. AMETEK is not responsible for blowers driven beyond factory specified speed, temperature, pressure, flow or without proper alignment. Actual performance will vary depending on the operating environment and application. AMETEK products are not designed for and should not be used in medical life support applications. AMETEK reserves the right to revise its products without notification. The above characteristics represent standard products. For product designed to meet specific applications, contact AMETEK Dynamic Fluid Solutions Sales department.

Low Voltage Brushless DC Blowers

4.5" (114mm) BLDC Low-Voltage Blower



12/24 VDC

INCH
[MM]

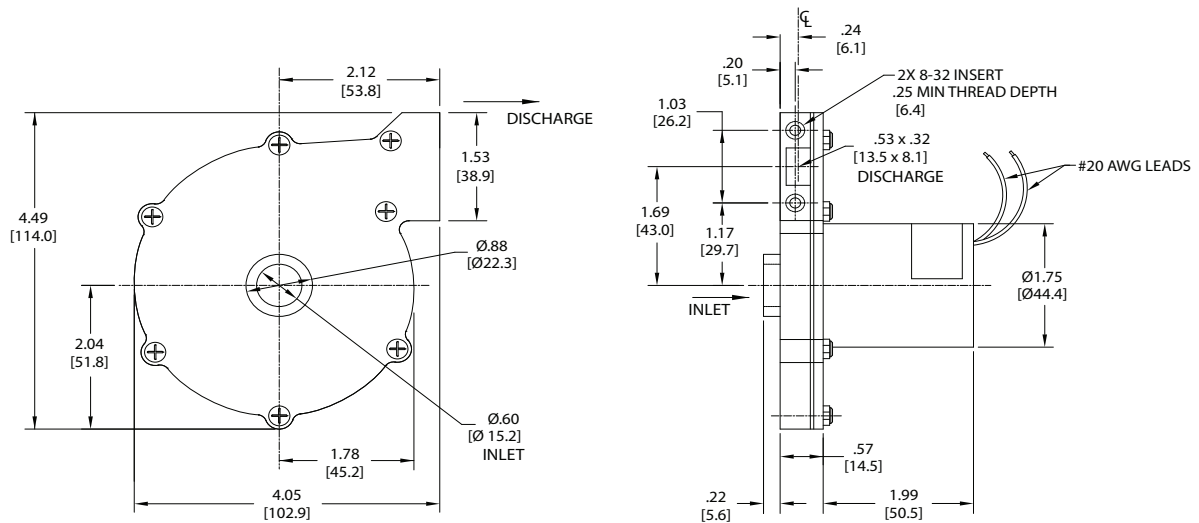

Specification	Units	Part/ Model Number	
		119494	119395
Voltage	VDC	6-14	16-28
Stages	-	1	1
Max Sealed Pressure	in. H2O	37.1	37.8
	mbar	92.4	94.2
Max Open Flow Rate	CFM	10.9	10.6
	m3/hr	18.5	18

Notes:

- **Temperature:** Working Air: 0°C to 45°C, Ambient Air: 0°C to 45°C, Storage: -40°C to 85°C.
- Customized performance available upon request. Please contact AMETEK Technical & Industrial Products' Marketing and Sales Department.
- When used as a vacuum, the blower performance might be less than shown herein, depending on the operating point.
- Please observe proper polarity for power connections. Improper connections will damage the blower's electronics.
- **Optional** - Motor configuration available with connection to external controller.
- **Optional** - 2-Wire Operation: The 3.0, 3.3, 4.5 inch Windjammers operate with a simple two-wire configuration. The blower speed is directly proportional to the supply voltage, and there is no separate speed command signal input or speed setting via potentiometer. The supply voltage powers both the motor winding and the motor controller. Operating points below the minimum supply voltage stated in the chart above can be achieved by providing a third wire to power the motor controller separately from the motor winding. This feature is available upon request.
- **Weight** = 13 oz / .4 Kg
- **Optional Tachometer Output:** A square wave output whose signal is 2x the blower rotational frequency.

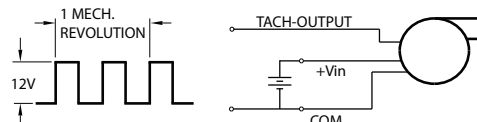

This document is for informational purposes only and should not be considered as a binding description of the products or their performance in all applications. The performance data on this page depicts typical performance under controlled laboratory conditions. AMETEK is not responsible for blowers driven beyond factory specified speed, temperature, pressure, flow or without proper alignment. Actual performance will vary depending on the operating environment and application. AMETEK products are not designed for and should not be used in medical life support applications. AMETEK reserves the right to revise its products without notification. The above characteristics represent standard products. For product designed to meet specific applications, contact AMETEK Dynamic Fluid Solutions Sales department.



Typical Performance

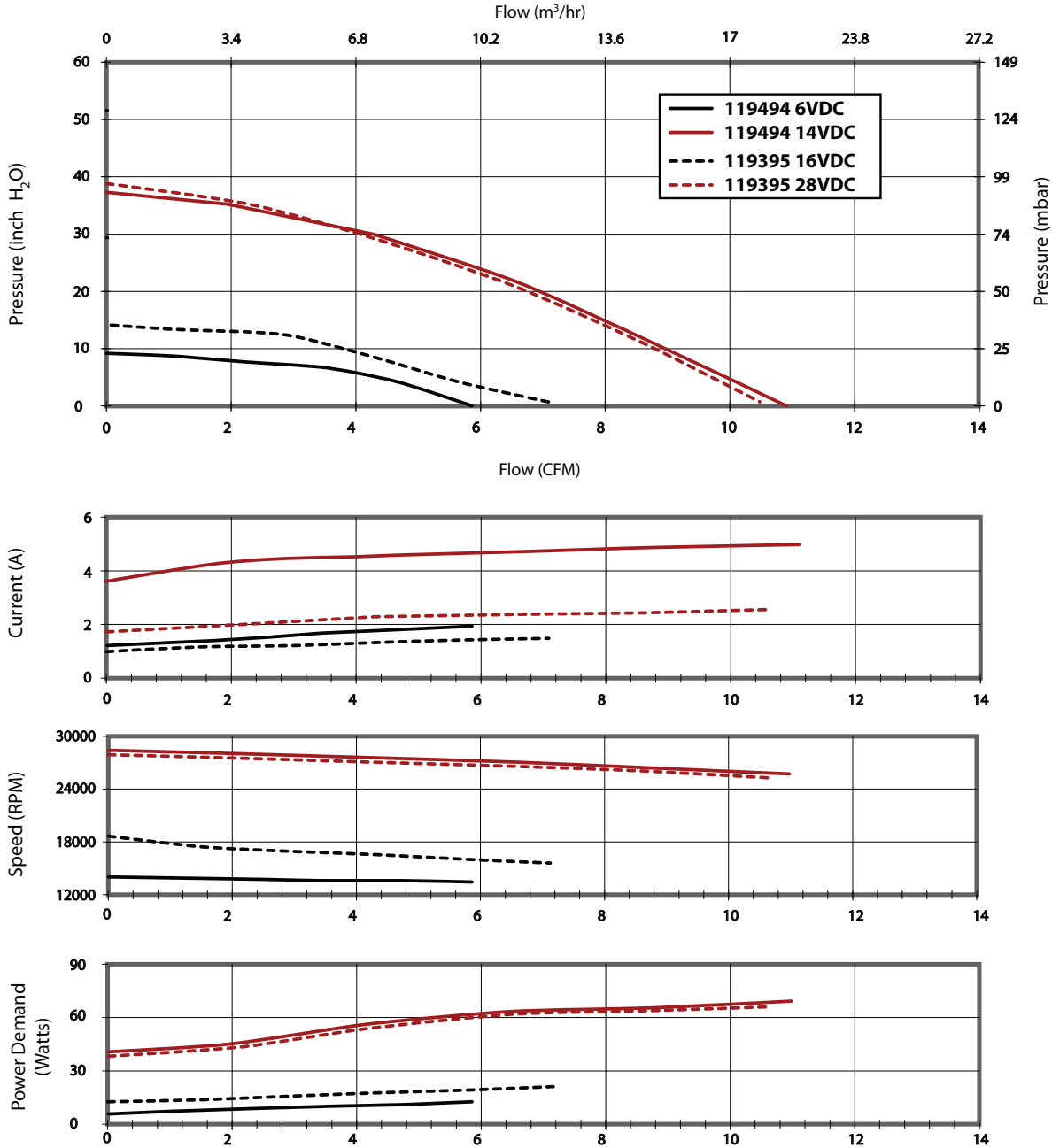

Data presented represents blower performance at STANDARD AIR DENSITY, .075 lb/ft³ (29.92" Hg, Sea Level, 68° F)
 Vacuum performance available upon request.

This document is for informational purposes only and should not be considered as a binding description of the products or their performance in all applications. The performance data on this page depicts typical performance under controlled laboratory conditions. AMETEK is not responsible for blowers driven beyond factory specified speed, temperature, pressure, flow or without proper alignment. Actual performance will vary depending on the operating environment and application. AMETEK products are not designed for and should not be used in medical life support applications. AMETEK reserves the right to revise its products without notification. The above characteristics represent standard products. For product designed to meet specific applications, contact AMETEK Dynamic Fluid Solutions Sales department.

Low Voltage Brushless DC Blowers



5.1" (130mm) BLDC Low-Voltage Blower

24 VDC

INCH
[MM]

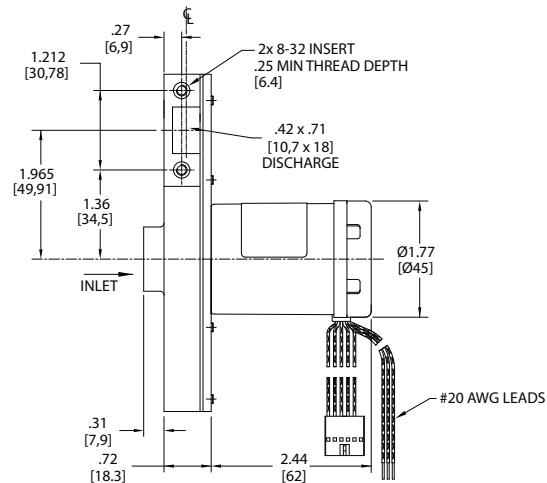
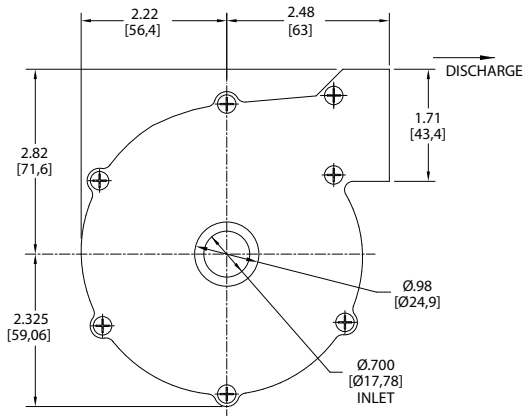

Specification	Units	Part/ Model Number
		150193
Voltage	VDC	24
Stages	-	1
Max Sealed Pressure	in. H2O	50.9
	mbar	126.8
Max Open Flow Rate	CFM	26.3
	m3/hr	44.7

Notes:

- This blower is designed to operate with an external 3-phase controller such as AMETEK's model 48140. Speed control method is a function of the controller that drives the blower. If using AMETEK's 48140, the controller can be set to control speed by potentiometer adjustment or by 0-5V analog speed command. Customized controller functions are available - contact AMETEK sales to inquire.
- **Temperature:** Working Air: 0°C to 45°C, Ambient Air: 0°C to 45°C, Storage: -40°C to 85°C.
- Customized performance available upon request. Please contact AMETEK Technical & Industrial Products' Marketing and Sales Department.
- When used as a vacuum, the blower performance might be less than shown herein, depending on the operating point.
- Product includes a two (2) plane balancing option for reduced vibration.
- **Weight** = 16 oz / .5 kg

This document is for informational purposes only and should not be considered as a binding description of the products or their performance in all applications. The performance data on this page depicts typical performance under controlled laboratory conditions. AMETEK is not responsible for blowers driven beyond factory specified speed, temperature, pressure, flow or without proper alignment. Actual performance will vary depending on the operating environment and application. AMETEK products are not designed for and should not be used in medical life support applications. AMETEK reserves the right to revise its products without notification. The above characteristics represent standard products. For product designed to meet specific applications, contact AMETEK Dynamic Fluid Solutions Sales department.

Typical Performance

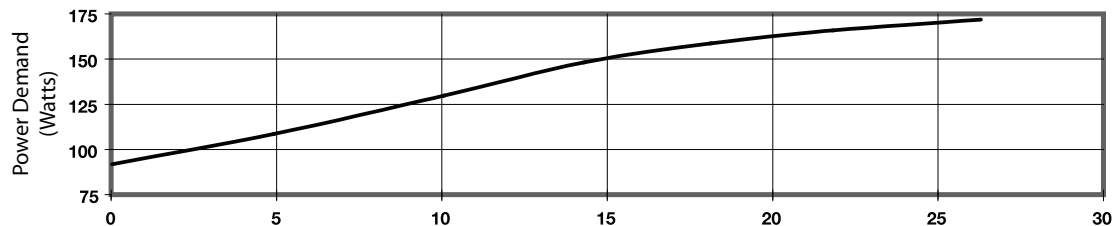
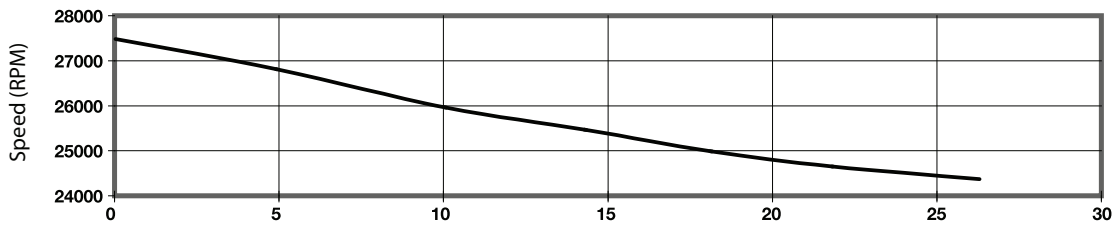
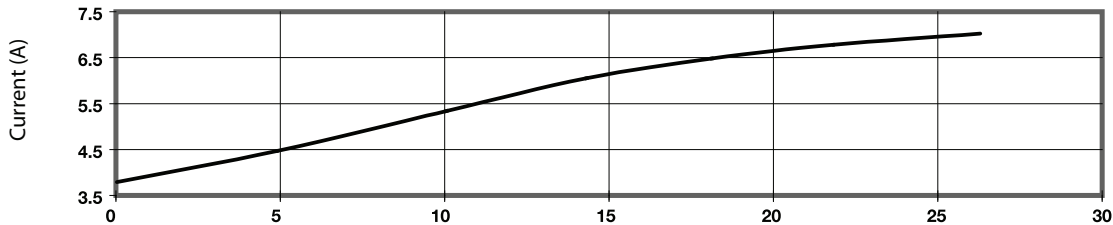
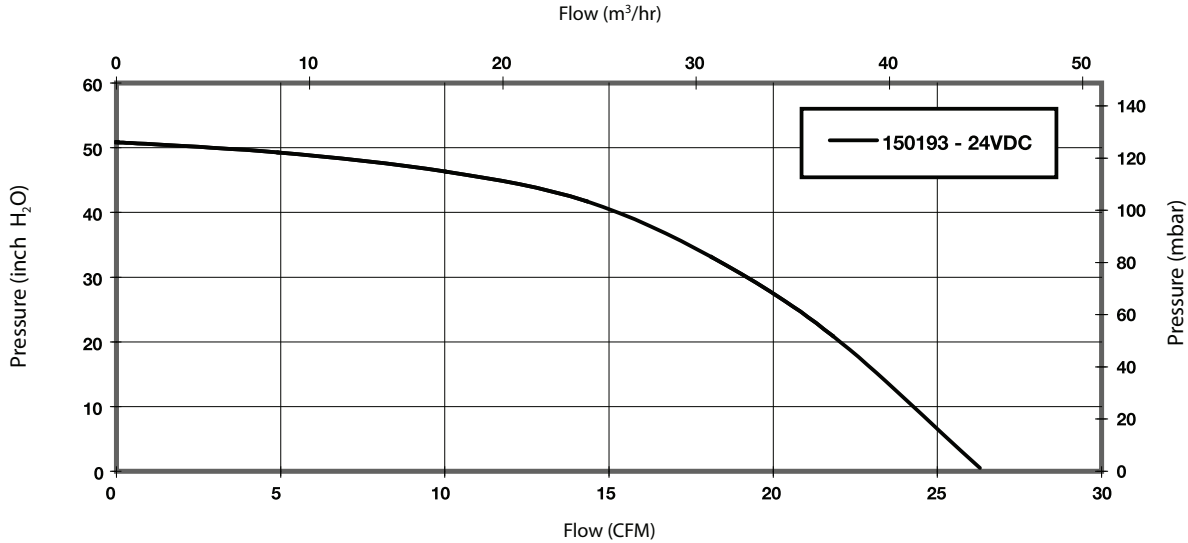

Data presented represents blower performance at STANDARD AIR DENSITY, .075 lb/ft³ (29.92" Hg, Sea Level, 68° F)
 Vacuum performance available upon request.

This document is for informational purposes only and should not be considered as a binding description of the products or their performance in all applications. The performance data on this page depicts typical performance under controlled laboratory conditions. AMETEK is not responsible for blowers driven beyond factory specified speed, temperature, pressure, flow or without proper alignment. Actual performance will vary depending on the operating environment and application. AMETEK products are not designed for and should not be used in medical life support applications. AMETEK reserves the right to revise its products without notification. The above characteristics represent standard products. For product designed to meet specific applications, contact AMETEK Dynamic Fluid Solutions Sales department.

AMETEK *Windjammer* Low Voltage Brushless DC blowers offer a wide range of performance for applications with power supplies of 72 VDC and less. The following pages detail each model family, including performance, size, and input voltage.

All brushless DC blowers require an electronic controller for operation. Most of the model families herein are offered with an onboard controller, and there are features and/or options available for customization.

Speed Control: Among the low voltage model families there are several methods for modulating blower speed.

Potentiometer Adjustment → the specified supply voltage is applied to power the blower and the speed is set by simply adjusting a potentiometer on the side of the blower.

Analog Speed Command Signal → blower speed is proportional to an analog command signal. Depending on the particular model, the range of the command signal is either 0-4V, 0-5V, or adjustable within 0-10V.

- (i) For *5.0 inch Windjammer* models equipped with analog speed command, blowers operate on a 0-4V command signal. Maximum speed is reached at 4V or less depending on the blower's operating point. The speed command pin may be connected to the blower's 12V or 24V V_{in} pin to ensure full speed.
- (ii) The *5.7 inch Windjammer* models have a calibration potentiometer that allows the user to set the range over which the speed command signal operates within a 0-10V range, or to precisely calibrate a group of blowers to the same speed for a given command voltage and operating condition.
- (iii) Blowers designed for one of AMETEK's low voltage external controllers can be configured to modulate speed via either a 0-5V analog command signal or potentiometer adjustment as described above.

2-Wire Operation → The *3.0, 3.3, and 4.5 inch Windjammers* operate with a different type of controller than other model families. These blowers have a simple two-wire configuration. The blower speed is directly proportional to the supply voltage, and there is no separate speed command signal input. The supply voltage powers both the motor winding and the motor controller. Operating points below the minimum specified supply voltage can be achieved by providing a third wire to power the motor controller separately from the motor winding. This feature is available upon request. The specification pages for each of these blower models list the supply voltage range.

Note: None of the blowers herein are designed to maintain constant speed if the blower operating point changes. The speed will change with changing load (the amount of backpressure), even if the speed control remains fixed.

Tachometer Output: A square wave output that is proportional to blower speed comes as a standard feature in the 24VDC *5.7 inch Windjammer* models, and it's an option that is available in the *3.0, 3.3, and 4.5 inch Windjammers*. The output signal is a square wave whose signal is 2x the blowers rotational frequency:

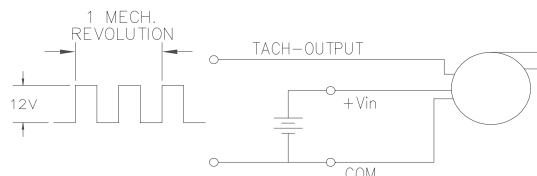

External Controllers: All of the models herein can be configured to operate with a separate external controller, and AMETEK's product offering does include several stand-alone controller models. The *5.0 inch Windjammer* model family has standard blower models already configured for external control. The other models (*3.0, 3.3, 4.5, and 5.7 inch Windjammers*) can be custom ordered to operate with an external controller - please contact an Ametek sales representative to inquire. **Note:** the *5.1 inch Windjammer* must use an external controller - it is not available with internal controller at this time.

This document is for informational purposes only and should not be considered as a binding description of the products or their performance in all applications. The performance data on this page depicts typical performance under controlled laboratory conditions. AMETEK is not responsible for blowers driven beyond factory specified speed, temperature, pressure, flow or without proper alignment. Actual performance will vary depending on the operating environment and application. AMETEK products are not designed for and should not be used in medical life support applications. AMETEK reserves the right to revise its products without notification. The above characteristics represent standard products. For product designed to meet specific applications, contact AMETEK Dynamic Fluid Solutions Sales department.

5.7 Bypass or Thru Flow: The 5.7 inch Windjammer product family offers two flow path configurations: Bypass or Thru Flow. The Bypass configuration separates the motor and controller from the working air, whereas the working air passes over the motor and controller in a Thru Flow configuration. The Thru Flow configuration shortens the package size but has a narrower range of operation due to thermal limitations of the motor and controller.

Locked-Rotor and Thermal Protection:

5.7 inch Windjammers → All models include locked rotor and thermal protection

5.1 inch Windjammer → Locked rotor protection depends on the controller being used. If using Ametek 48140 controller, locked rotor protection is enabled. No thermal protection.

5.0 inch Windjammers → All models with on-board controllers include locked rotor protection. If using an external controller, locked rotor protection depends on the controller design. Thermal protection is not available for this model family.

3.0, 3.3, and 4.5 inch Windjammers → These models have neither locked rotor nor thermal protection. Users are advised to include a fuse for circuit protection. See performance sheets for individual blower models for fuse sizing.

Other Features and Miscellaneous Notes:

- 5.0 inch Windjammers are available with inlet tube for connecting a hose to the blower inlet. See 5.0 inch Windjammer pages herein for details.
- 5.0 inch Windjammers can be equipped with an external balancing disk for applications with tight noise and vibration constraints. Contact AMETEK Sales for inquiries regarding this feature.
- 3.0, 3.3, and 4.5 inch Windjammers can be configured to have separate V_{in} for the controller and the motor, as mentioned above. This allows very low input voltage on the motor (low speed) without shutting down the drive electronics. The controller V_{in} can be configured to accept a specific supply voltage depending on an application's needs.
- 5.7 Windjammers designed for 48V and 72V input do not have an option for tachometer output at this time. 24V models have a tachometer output as a standard feature. Also, the analog speed command for 24V 5.7 Windjammer shares a common with the 24V supply voltage. For the 48V and 72V 5.7 Windjammers, the analog speed command input is isolated from the power supply input. See pages herein for specifics about each model.

This document is for informational purposes only and should not be considered as a binding description of the products or their performance in all applications. The performance data on this page depicts typical performance under controlled laboratory conditions. AMETEK is not responsible for blowers driven beyond factory specified speed, temperature, pressure, flow or without proper alignment. Actual performance will vary depending on the operating environment and application. AMETEK products are not designed for and should not be used in medical life support applications. AMETEK reserves the right to revise its products without notification. The above characteristics represent standard products. For product designed to meet specific applications, contact AMETEK Dynamic Fluid Solutions Sales department.

Low Voltage Brushless DC Blowers

5.0" (127mm) BLDC Low-Voltage Blower



12/24 VDC, High Flow System

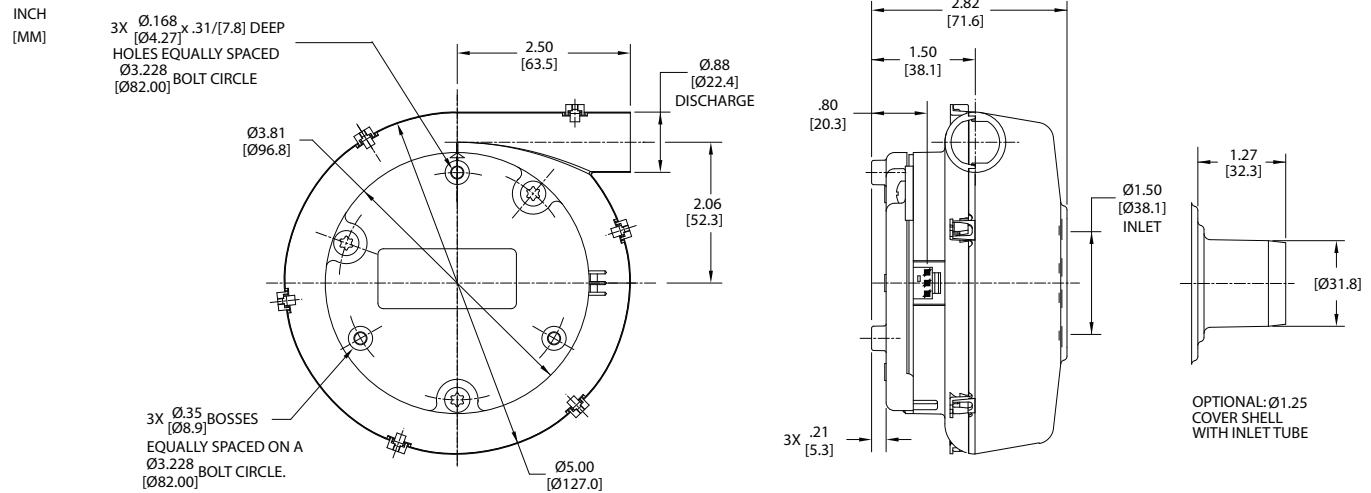

Specification	Units	Part/ Model Number			
		150166	119375	119378	119379
Voltage	VDC	12	24	24	24
Stages	-	1	1	1	1
Max. Sealed Pressure	in. H ₂ O	20.1	24.9	24.9	24.9
	mbar	50.1	62	62	62
Max Open Flow Rate	CFM	37.7	44.6	44.6	44.6
	m ³ /hr	64.1	75.8	75.8	75.8
Speed Control	-	0-4V Spd. Cmd.	External	Potent. Adjust.	0-4V Spd. Cmd.

Notes:

- **Temperature:** Working Air: 0°C to 45°C, Ambient Air: 0°C to 45°C, Storage: -40°C to 85°C.
- Customized performance available upon request. Please contact AMETEK Technical & Industrial Products' Marketing and Sales Department.
- When used as a vacuum, the blower performance might be less than shown herein, depending on the operating point.
- Models 119380 through 119385 can be configured and modified for two (2) plane balance option.
- **Optional** - cover shell with air inlet tube.
- **Weight** = 1.2 lb / .54 Kg

Potentiometer Adjustment (Potent. Adjust.) - The specified supply voltage is applied to power the blower and the speed is set by adjusting a potentiometer on the side of the blower.

0-4V Speed Command (0-4V Spd. Cmd.) - Blower speed is proportional to a 0-4V command signal. Maximum speed is reached at 4V or less depending on the blower's operating point. The speed command pin may be connected to the blower's 12V or 24V pin to ensure full speed.

External Control - Designed to operate with an external controller such as AMETEK's model 48133.

This document is for informational purposes only and should not be considered as a binding description of the products or their performance in all applications. The performance data on this page depicts typical performance under controlled laboratory conditions. AMETEK is not responsible for blowers driven beyond factory specified speed, temperature, pressure, flow or without proper alignment. Actual performance will vary depending on the operating environment and application. AMETEK products are not designed for and should not be used in medical life support applications. AMETEK reserves the right to revise its products without notification. The above characteristics represent standard products. For product designed to meet specific applications, contact AMETEK Dynamic Fluid Solutions Sales department.



Typical Performance

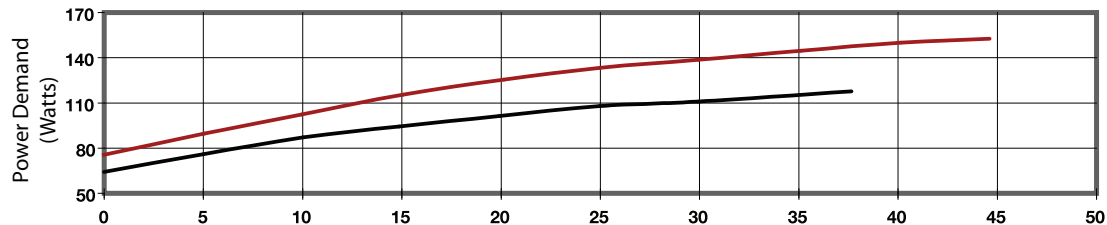
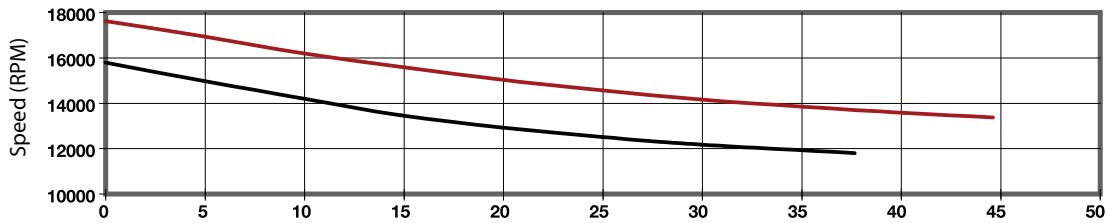
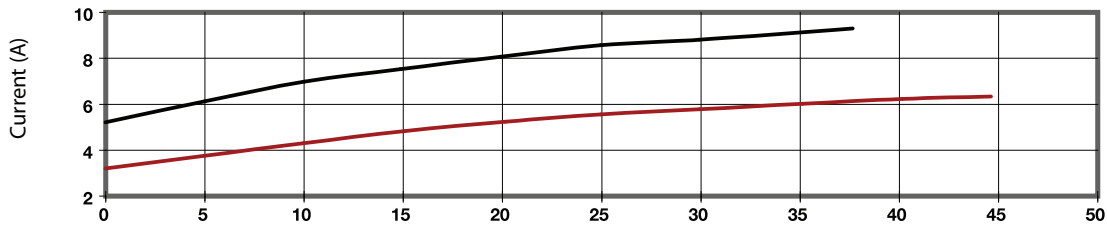
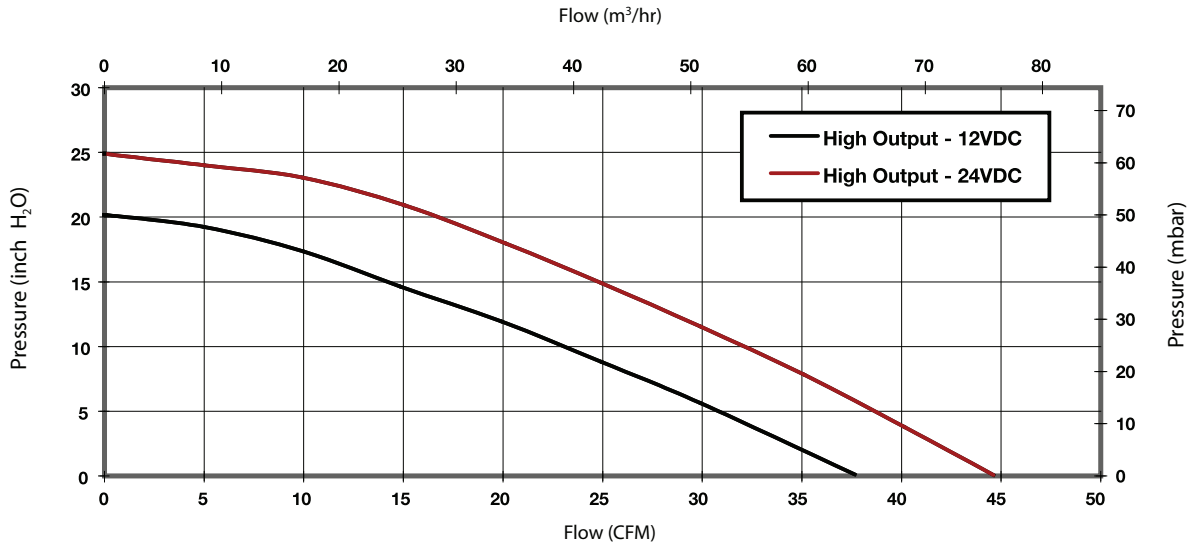

Data presented represents blower performance at STANDARD AIR DENSITY, .075 lb/ft³ (29.92" Hg, Sea Level, 68° F)
 Vacuum performance available upon request.

This document is for informational purposes only and should not be considered as a binding description of the products or their performance in all applications. The performance data on this page depicts typical performance under controlled laboratory conditions. AMETEK is not responsible for blowers driven beyond factory specified speed, temperature, pressure, flow or without proper alignment. Actual performance will vary depending on the operating environment and application. AMETEK products are not designed for and should not be used in medical life support applications. AMETEK reserves the right to revise its products without notification. The above characteristics represent standard products. For product designed to meet specific applications, contact AMETEK Dynamic Fluid Solutions Sales department.

Low Voltage Brushless DC Blowers



5.0" (127mm) BLDC Low-Voltage Blower

12/24 VDC, Standard Flow System

INCH

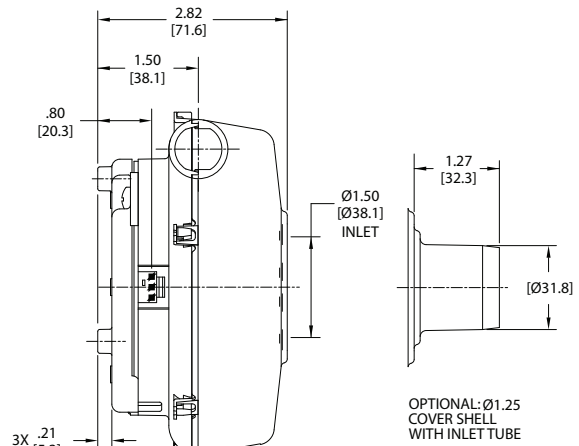
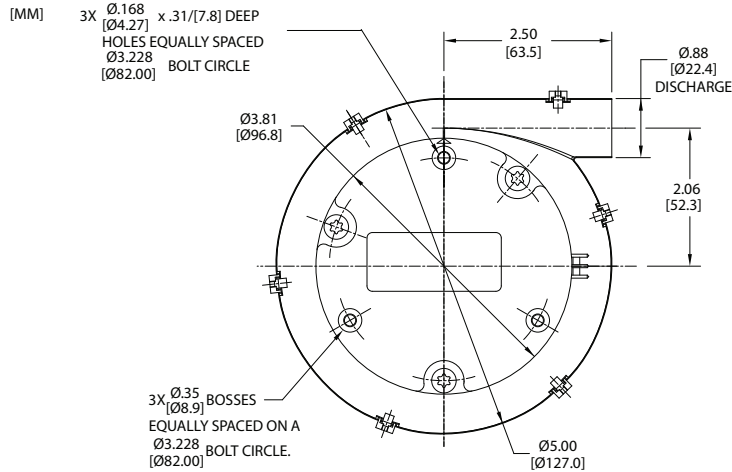

Specification	Units	Part/ Model Number					
		119380	119381	119382	119383	119384	119385
Voltage	VDC	12	12	12	24	24	24
Stages	-	1	1	1	1	1	1
Max. Sealed Pressure	in. H ₂ O	13.5	13.5	13.5	12.5	12.5	12.5
	mbar	33.6	33.6	33.6	31.1	31.1	31.1
Max Open Flow Rate	CFM	32.3	32.3	32.3	35.3	35.3	35.3
	m ³ /hr	54.9	54.9	54.9	60	60	60
Speed Control	-	External	Potent. Adjust.	0-4V Spd. Cmd.	External	Potent. Adjust.	0-4V Spd. Cmd.

Notes:

- **Temperature:** Working Air: 0°C to 45°C, Ambient Air: 0°C to 45°C, Storage: -40°C to 85°C.
- Customized performance available upon request. Please contact AMETEK Technical & Industrial Products' Marketing and Sales Department.
- When used as a vacuum, the blower performance might be less than shown herein, depending on the operating point.
- Models 119380 thru 119385 can be configured and modified for two (2) plane balance option.
- **Optional** - cover shell with air inlet tube.
- **Weight** = 1.2 lb / .54 Kg

Potentiometer Adjustment (Potent. Adjust.) - The specified supply voltage is applied to power the blower and the speed is set by adjusting a potentiometer on the side of the blower.

0-4V Speed Command (0-4V Spd. Cmd.) - Blower speed is proportional to a 0-4V command signal. Maximum speed is reached at 4V or less depending on the blower's operating point. The speed command pin may be connected to the blower's 12V or 24V pin to ensure full speed.

External Control - Designed to operate with an external controller such as AMETEK's model 48133.

This document is for informational purposes only and should not be considered as a binding description of the products or their performance in all applications. The performance data on this page depicts typical performance under controlled laboratory conditions. AMETEK is not responsible for blowers driven beyond factory specified speed, temperature, pressure, flow or without proper alignment. Actual performance will vary depending on the operating environment and application. AMETEK products are not designed for and should not be used in medical life support applications. AMETEK reserves the right to revise its products without notification. The above characteristics represent standard products. For product designed to meet specific applications, contact AMETEK Dynamic Fluid Solutions Sales department.



Typical Performance

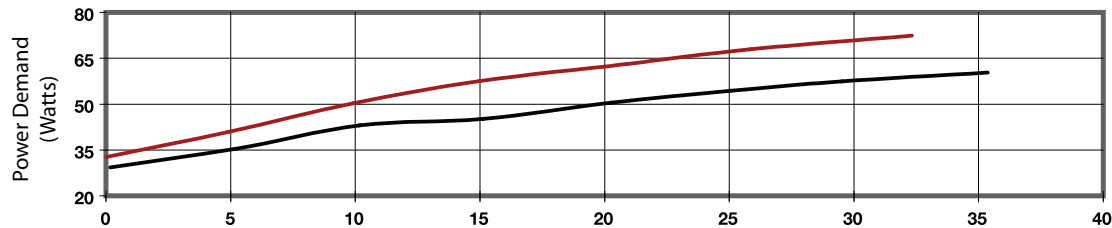
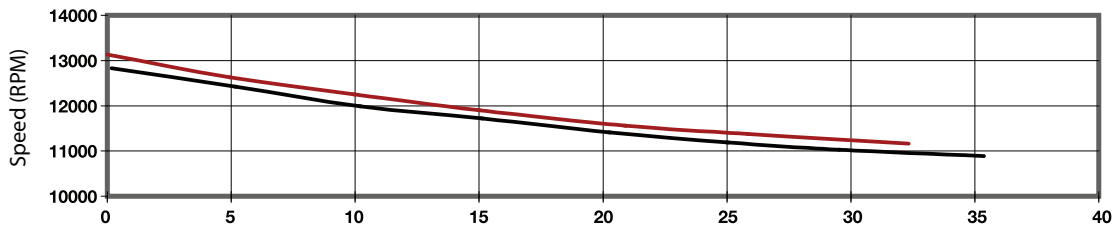
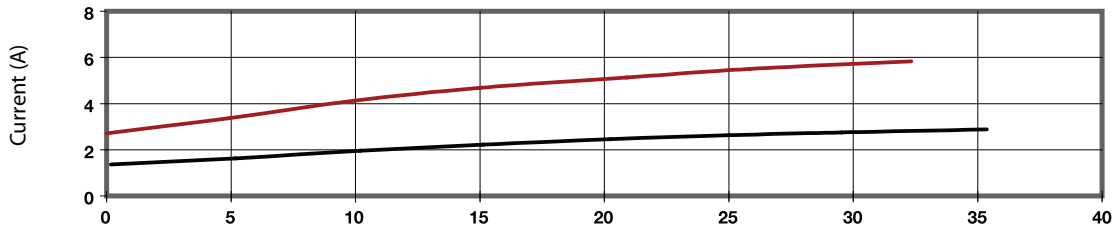
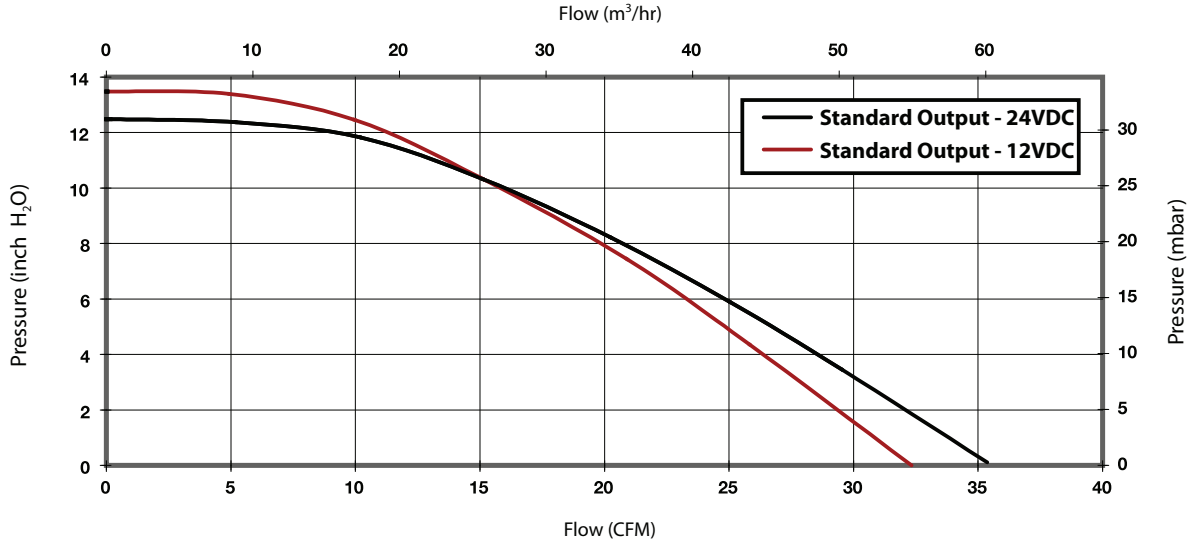

Data presented represents blower performance at STANDARD AIR DENSITY, .075 lb/ft³ (29.92" Hg, Sea Level, 68° F)
 Vacuum performance available upon request.

This document is for informational purposes only and should not be considered as a binding description of the products or their performance in all applications. The performance data on this page depicts typical performance under controlled laboratory conditions. AMETEK is not responsible for blowers driven beyond factory specified speed, temperature, pressure, flow or without proper alignment. Actual performance will vary depending on the operating environment and application. AMETEK products are not designed for and should not be used in medical life support applications. AMETEK reserves the right to revise its products without notification. The above characteristics represent standard products. For product designed to meet specific applications, contact AMETEK Dynamic Fluid Solutions Sales department.