



Lamb Electric

Model: 122444-17

SPECIAL FEATURES

- 1500+ hours life (curved brush)
- 50/60 Hz
- Up to 42% Overall Efficiency
- High efficient cooling system
- Lamb "Green Power Label"
- UL & cUL recognized, category PRGY2 (E47185)
- Locked-rotor, blocked cooling air and running overload protection

DESCRIPTION

- 240 volts AC
- Two-stage tapered fan
- 6.6" / 162 mm diameter
- Improved sound quality
- "True" tangential discharge bracket
- High-Efficiency "Galaxy" lamination
- Double ball bearings; 10mm output

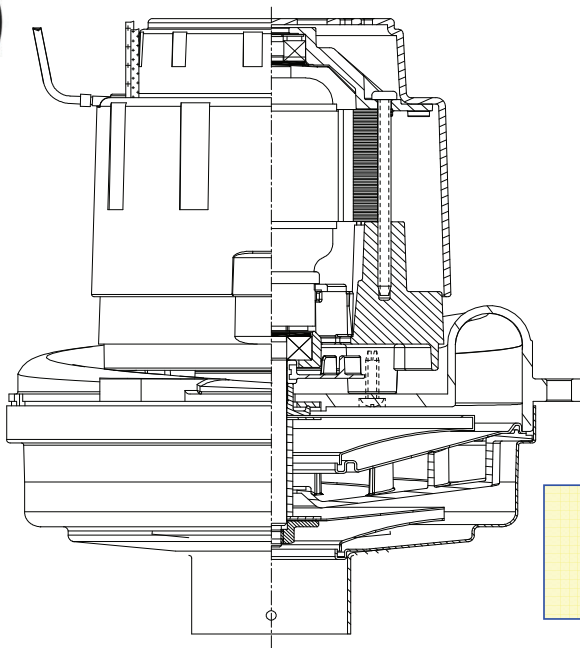

DESIGN APPLICATION

- Commercial and Residential Central Cleaning Systems
- Car wash vac and blower systems
- Equipment operating in environments requiring separation of working air from motor ventilating air
- Designed to handle clean, dry, filtered air only

**PEAK AIRWATTS**  
**513**  
Calculated in accordance with ASTM F2105

TYPICAL MOTOR PERFORMANCE.\*

(At 240 volts, 60Hz, test data is corrected to standard conditions of 29.92 Hg, 68° F.)

ASTM DATA

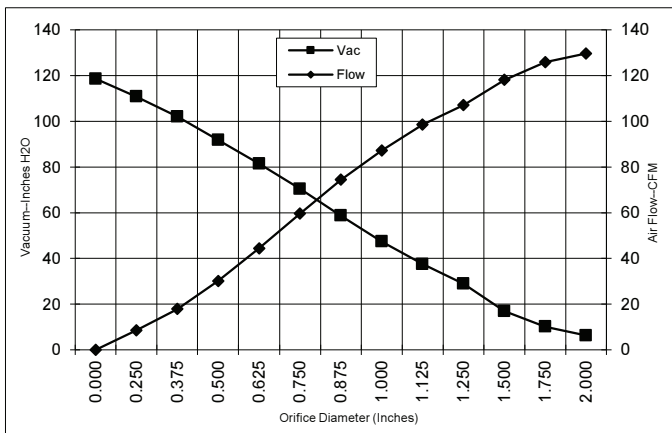

Orifice (Inches)	Amps	Watts (In)	RPM	Vac (In.H2O)	Flow (CFM)	Air Watts
2.000	5.5	1243	21544	6.2	129.6	95
1.750	5.5	1244	21522	10.1	125.8	150
1.500	5.6	1247	21490	17.0	118.1	235
1.250	5.6	1249	21448	28.9	107.1	363
1.125	5.6	1257	21389	37.5	98.5	434
1.000	5.6	1252	21432	47.4	87.2	485
0.875	5.5	1236	21549	58.7	74.4	513
0.750	5.3	1195	21963	70.4	59.7	493
0.625	5.0	1124	22621	81.4	44.4	424
0.500	4.5	1030	23657	91.9	30.1	324
0.375	4.0	922	24950	102.0	17.8	214
0.250	3.6	835	26322	110.8	8.5	111
0.000	3.3	767	27587	118.5	0.0	0

METRIC DATA

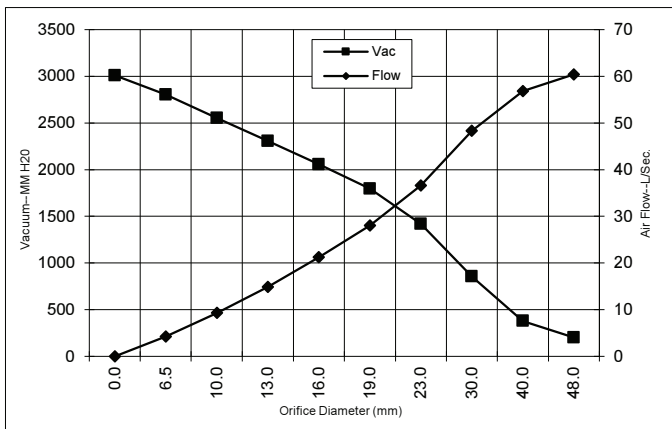

Orifice (mm)	Amps	Watts (In)	RPM	Vac (mm H2O)	Flow (L/Sec)	Air Watts
48.0	5.5	1244	21534	202	60.4	119
40.0	5.6	1246	21499	379	56.8	210
30.0	5.6	1254	21416	855	48.3	402
23.0	5.5	1240	21519	1420	36.6	506
19.0	5.3	1194	21976	1795	28.0	492
16.0	5.0	1127	22595	2057	21.2	427
13.0	4.6	1040	23553	2307	14.9	334
10.0	4.1	939	24756	2553	9.3	230
6.5	3.6	839	26253	2803	4.3	116
0.0	3.3	767	27587	3010	0.0	0

Note: Metric Performance data is calculated from the ASTM data above.

\* Data represents performance of a typical motor sampled from a large production quantity. Individual motor data may vary due to normal manufacturing variations.

Test Specs:	120 Volts	Minimum Sealed Vacuum: 108"	ORIFICE:	7/8"	Min. Vacuum: 54"	Maximum Watts:	1260
-------------	-----------	-----------------------------	----------	------	------------------	----------------	------

**DIMENSIONS**



**NOTES:**

1. LEADS: 18GA. STRANDED, POWER LEADS BLACK AND WHITE, GROUNDING LEAD GREEN OR GREEN WITH YELLOW STRIPE.
2. MOTOR IDENTIFICATION: MANUFACTURER'S NAME, MODEL NUMBER, VOLTAGE, FREQUENCY, INSPECTORS CODE WITH "FF" SUFFIX, DATE OF MANUFACTURE, AGENCY RECOGNITION CODE, PLANT LOCATION CODE, PATENT PENDING\* AND COUNTRY OF ORIGIN.
3. MOUNTING MUST NOT RESTRICT THIS DIAMETER.
4. ALLOW [0.0026 SQ M]/4.0 SQ IN. (MIN.) FOR COOLING AIR INTAKE.
5. COOLING AIR INTAKE MUST BE SEPARATED FROM COOLING AIR EXHAUST.
6. COOLING AIR EXHAUST MUST BE SEPARATED FROM VACUUM EXHAUST.

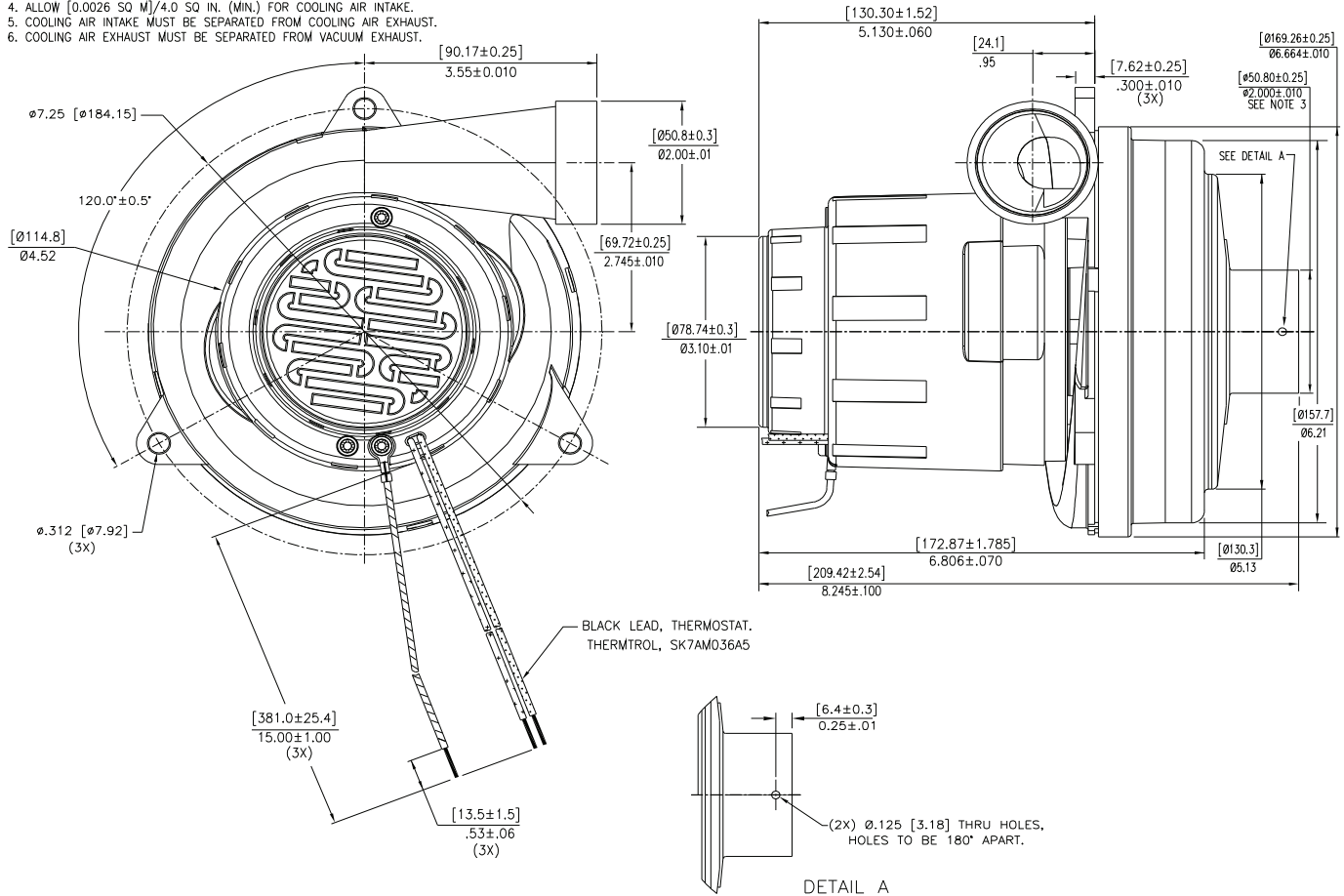

**IMPORTANT NOTE:** Pictorial and dimensional data are subject to change without notice. Contact factory for current revision levels.

**WARNING** - When using AMETEK Floorcare & Specialty Motors (F&SM) bypass motors in machines that come in contact with foam, liquid (including water), or other foreign substances, the machine must be designed and constructed to prevent those substances from reaching the fan system, motor housing, and electrical components. F&SM vacuum motors other than hazardous duty models should not be applied in machines that come in contact with dry chemicals or other volatile materials. Failure to observe these precautions could cause flashing (depending on volatility) or electrical shock which could result in property damage and severe bodily injury, including death in extreme cases. All applications incorporating F&SM motors should be submitted to appropriate organizations or agencies for testing specifically related to the safety of your equipment.

**AMETEK Dynamic Fluid Solutions**  
[www.ametekdfs.com](http://www.ametekdfs.com)