



**Floorcare & Specialty Motors**

**Model: 122315-18**

**DESCRIPTION**

- Two stage
- 120 volts
- 5.7"/145 mm diameter
- Double ball bearings
- Single speed
- "Eternity" (curved) Brush Mech
- Peripheral bypass discharge
- Thermoset fan end bracket
- Stamped steel End-bracket

**DESIGN APPLICATION**

- Equipment operating in environments requiring separation of working air from motor ventilating air
- Designed to handle clean, dry, filtered air only

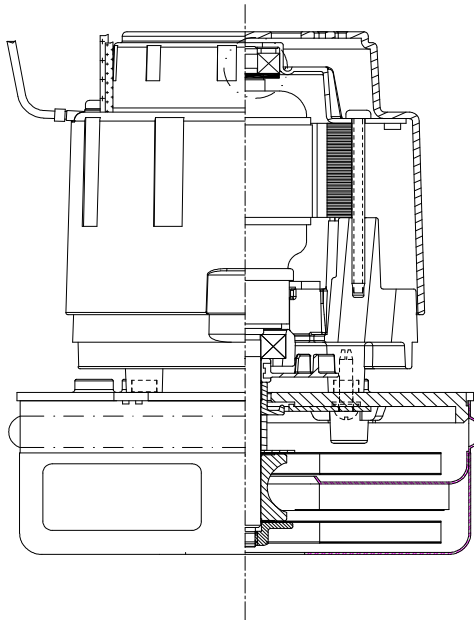

**SPECIAL FEATURES**

- Suitable for 120 volt AC operation 50/60 Hz
- UL recognized, category PRGY2 (E47185)
- Provision for grounding
- "Eternity" Brush Mechs
- Skeleton-frame design
- Bearing Protection (for wet applications)
- The Lamb Electric vacuum motor line offers a wide range of performance levels to meet design needs

**TYPICAL MOTOR PERFORMANCE.\***

(At 120 volts, 60Hz, test data is corrected to standard conditions of 29.92 Hg, 68°F.)

**ASTM DATA**

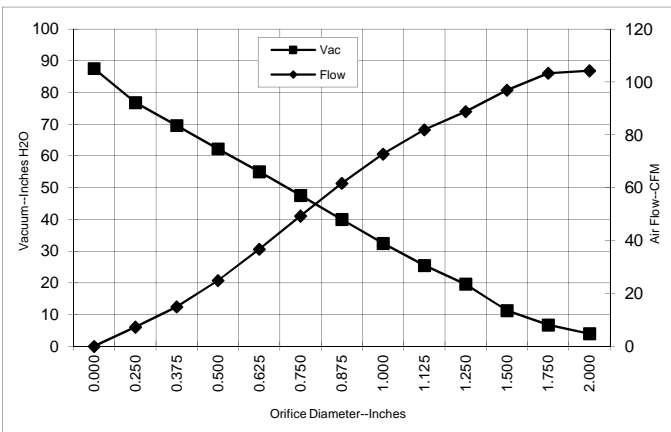

Orifice (Inches)	Amps	Watts (In)	RPM	Vac (In.H2O)	Flow (CFM)	Air Watts
2.000	7.8	893	18279	4.0	104.2	49
1.750	7.9	900	18278	6.7	103.3	82
1.500	8.0	911	17983	11.3	96.9	128
1.250	8.2	929	17689	19.6	88.8	204
1.125	8.2	931	17689	25.5	81.9	245
1.000	8.2	931	17689	32.5	72.7	277
0.875	8.0	916	17983	40.0	61.7	289
0.750	7.7	833	18278	47.6	49.3	275
0.625	7.3	837	18868	55.1	36.7	237
0.500	6.7	776	19458	62.3	24.9	182
0.375	6.2	715	20637	69.6	14.9	122
0.250	5.7	665	21521	76.8	7.3	66
0.000	5.4	625	22406	87.6	0.0	0

**METRIC DATA**

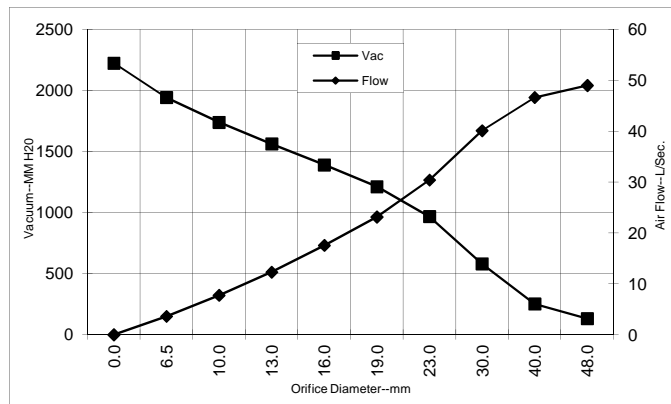

Orifice (mm)	Amps	Watts (In)	RPM	Vac (mm H2O)	Flow (L/Sec)	Air Watts
48.0	7.9	896	18279	132	49.0	63
40.0	8.0	908	18072	252	46.6	114
30.0	8.2	930	17689	580	40.1	227
23.0	8.0	920	17910	968	30.4	286
19.0	7.7	833	18290	1212	23.1	274
16.0	7.3	837	18844	1391	17.6	239
13.0	6.8	782	19399	1563	12.3	188
10.0	6.3	724	20460	1740	7.8	131
6.5	5.7	668	21477	1943	3.6	69
0.0	5.4	625	22406	2224	0.0	0

Note: Metric performance data is calculated from the ASTM data above.

\* Data represents performance of a typical motor sampled from a large production quantity. Individual motor data may vary due to normal manufacturing variations.

<b>Test Specs:</b>	120 volts	<b>Minimum Sealed Vacuum:</b>	78"	<b>ORIFICE:</b>	7/8 "	<b>Minimum Vacuum:</b>	34.0	<b>Maximum Watts:</b>	990
--------------------	-----------	-------------------------------	-----	-----------------	-------	------------------------	------	-----------------------	-----

**DIMENSIONS**

**NOTES:**

1. LEADS: 18GA. STRANDED, POWER LEADS BLACK AND WHITE. GROUNDING LEAD GREEN OR GREEN WITH YELLOW STRIPE.
2. MOTOR IDENTIFICATION: MANUFACTURER'S NAME, MODEL NUMBER, VOLTAGE, FREQUENCY, INSPECTORS CODE WITH "FF" SUFFIX, DATE OF MANUFACTURE, AGENCY RECOGNITION CODE, PLANT LOCATION CODE, PATENT PENDING\* AND COUNTRY OF ORIGIN.
3. MOUNTING MUST NOT RESTRICT THIS DIAMETER.
4. ALLOW [0.0026 SQ M]/4.0 SQ IN. (MIN.) FOR COOLING AIR INTAKE.
5. COOLING AIR INTAKE MUST BE SEPARATED FROM COOLING AIR EXHAUST.
6. COOLING AIR EXHAUST MUST BE SEPARATED FROM VACUUM EXHAUST.

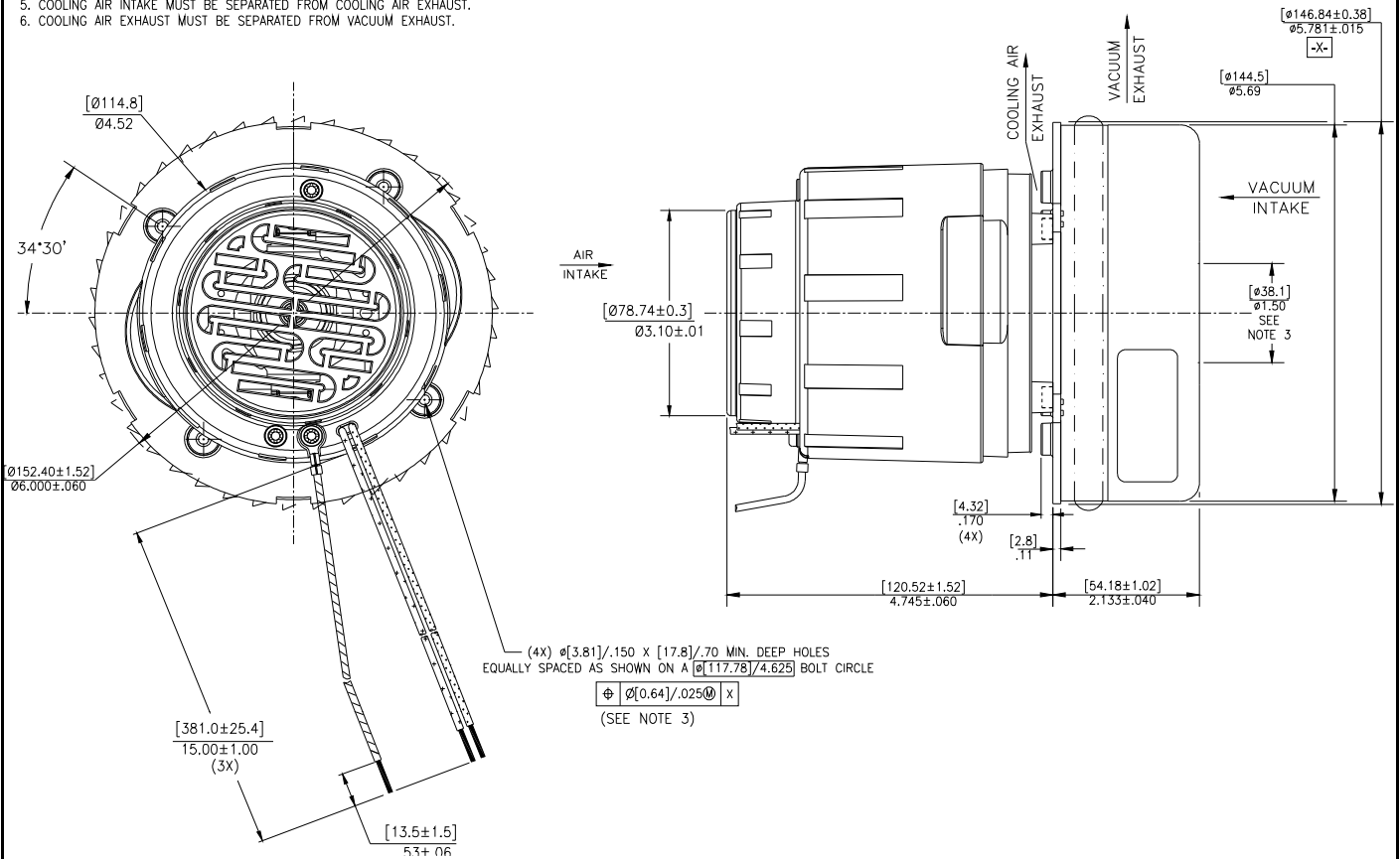

**IMPORTANT NOTE:** Pictorial and dimensional data are subject to change without notice. Contact factory for current revision levels.

**WARNING** - When using AMETEK Lamb Electric bypass motors in machines that come in contact with foam, liquid (including water), or other foreign substances, the machine must be designed and constructed to prevent those substances from reaching the fan system, motor housing, and electrical components. Lamb Electric vacuum motors other than hazardous duty models should not be applied in machines that come in contact with dry chemicals or other volatile materials. Failure to observe these precautions could cause flashing (depending on volatility) or electrical shock which could result in property damage and severe bodily injury, including death in extreme cases. All applications incorporating Lamb Electric motors should be submitted to appropriate organizations or agencies for testing specifically related to the safety of your equipment.

**AMETEK/Floorcare and Specialty Motors**  
 627 Lake Street  
 Kent, Ohio 44240  
 U.S.A.  
 www.ametekfsm.com