



**Floorcare & Specialty Motors**

**Model: 122237-18**



**DESCRIPTION**

- 24 volts DC
- Two-stage tapered fan
- 6.6" / 162 mm diameter
- Improved sound quality
- "True" tangential discharge bracket
- High-Efficiency "Galaxy" lamination
- Double ball bearings; 10mm output

**DESIGN APPLICATION**

- Commercial and Residential Central Cleaning Systems
- Car wash vac and blower systems
- Equipment operating in environments requiring separation of working air from motor ventilating air
- Designed to handle clean, dry, filtered air only

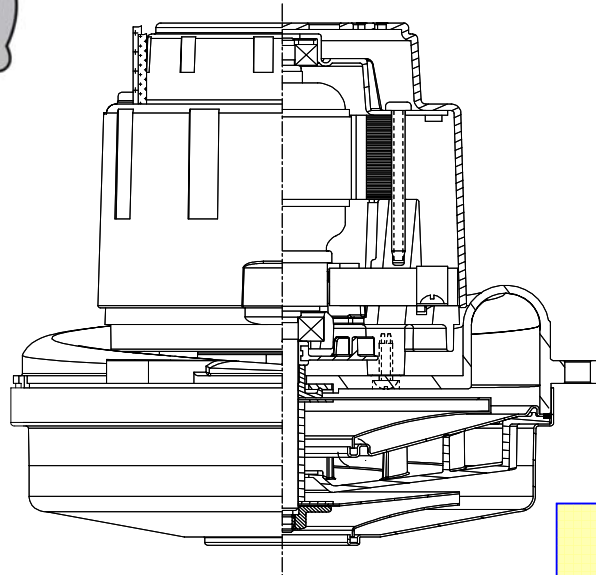

**SPECIAL FEATURES**

- 2000+ hours life
- 157 Peak Air Watts
- Up to 33% Overall Efficiency
- High efficient cooling system
- Lamb "Green Power Label"
- UL recognized, category PRGY2 (E47185)
- CSA certification pending
- New patent-pending bearing protection for wet applications.

**PEAK AIRWATTS**

**157**

Calculated in accordance with ASTM F2105

**TYPICAL MOTOR PERFORMANCE.\***

(At 24 volts DC, test data is corrected to standard conditions of 29.92 Hg, 68° F.)

**ASTM DATA**

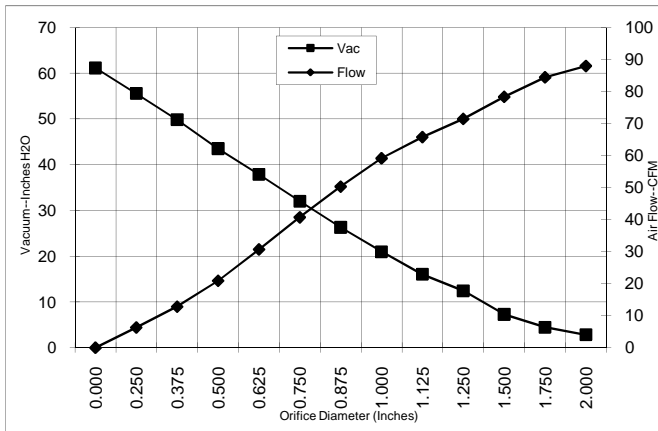

Orifice (Inches)	Amps	Watts (In)	RPM	Vac (In.H <sub>2</sub> O)	Flow (CFM)	Air Watts
2.000	19.2	462	13944	2.8	88.0	29
1.750	19.3	465	13944	4.4	84.4	44
1.500	19.4	466	13943	7.3	78.3	67
1.250	19.5	468	13967	12.4	71.4	104
1.125	19.5	468	13918	16.0	65.8	124
1.000	19.6	470	13896	21.0	59.1	145
0.875	19.5	469	13944	26.3	50.3	155
0.750	19.1	460	14209	32.0	40.7	153
0.625	18.4	443	14716	37.9	30.7	136
0.500	17.4	419	15439	43.5	20.9	106
0.375	16.0	387	16431	49.9	12.8	75
0.250	14.9	360	17397	55.6	6.3	41
0.000	14.0	338	18439	61.1	0.0	0

**METRIC DATA**

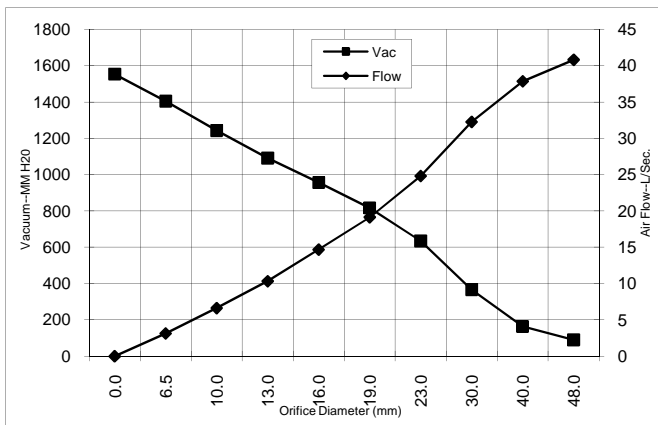

Orifice (mm)	Amps	Watts (In)	RPM	Vac (mm H <sub>2</sub> O)	Flow (L/Sec)	Air Watts
48.0	19.3	463	13944	90	40.8	36
40.0	19.4	466	13943	163	37.8	60
30.0	19.5	468	13940	366	32.2	115
23.0	19.5	469	13932	634	24.8	153
19.0	19.1	459	14219	816	19.1	153
16.0	18.4	444	14696	956	14.7	137
13.0	17.5	421	15367	1091	10.3	109
10.0	16.2	392	16282	1242	6.6	80
6.5	14.9	362	17349	1404	3.1	43
0.0	14.0	338	18439	1553	0.0	0

Note: Metric Performance data is calculated from the ASTM data above.

\* Data represents performance of a typical motor sampled from a large production quantity. Individual motor data may vary due to normal manufacturing variations.

<b>Test Specs:</b>	<b>24 VDC</b>	<b>Minimum Sealed Vacuum:</b>	<b>55.0</b>	<b>ORIFICE:</b>	<b>7/8"</b>	<b>Min. Vacuum:</b>	<b>23.5</b>	<b>Maximum Watts:</b>	<b>510</b>
--------------------	---------------	-------------------------------	-------------	-----------------	-------------	---------------------	-------------	-----------------------	------------

**DIMENSIONS**



**NOTES:**

1. LEADS: 18GA. STRANDED, POWER LEADS BLACK AND WHITE. GROUNDING LEAD GREEN OR GREEN WITH YELLOW STRIPE.
2. MOTOR IDENTIFICATION: MANUFACTURER'S NAME, MODEL NUMBER, VOLTAGE, FREQUENCY, INSPECTORS CODE WITH "FF" SUFFIX, DATE OF MANUFACTURE, AGENCY RECOGNITION CODE, PLANT LOCATION CODE, PATENT PENDING\* AND COUNTRY OF ORIGIN.
3. MOUNTING MUST NOT RESTRICT THIS DIAMETER.
4. ALLOW [0.0026 SQ M]/4.0 SQ IN. (MIN.) FOR COOLING AIR INTAKE.
5. COOLING AIR INTAKE MUST BE SEPARATED FROM COOLING AIR EXHAUST.
6. COOLING AIR EXHAUST MUST BE SEPARATED FROM VACUUM EXHAUST.

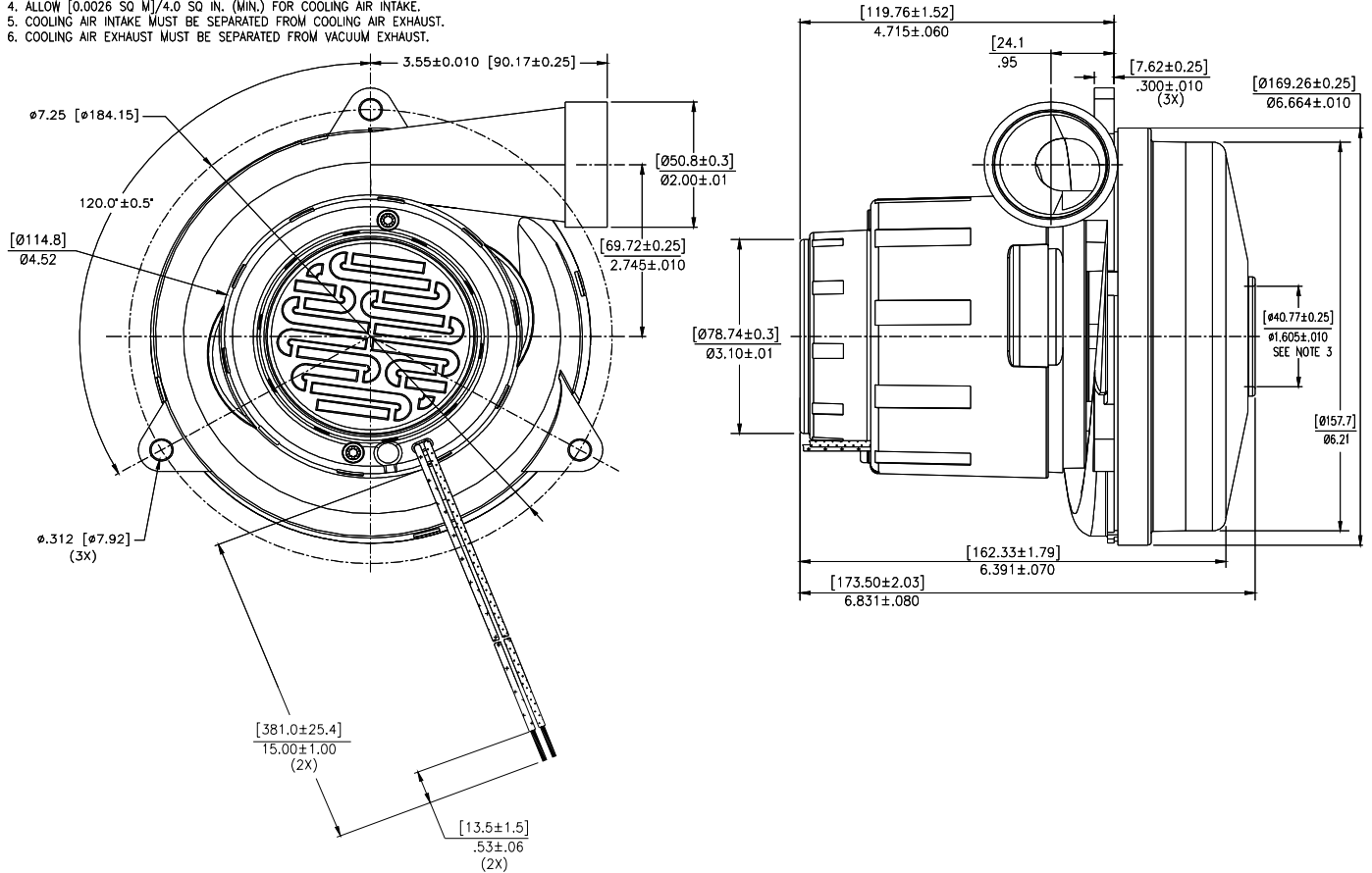

**IMPORTANT NOTE:** Pictorial and dimensional data are subject to change without notice. Contact factory for current revision levels.

**WARNING** - When using AMETEK Floorcare & Specialty Motors (F&SM) bypass motors in machines that come in contact with foam, liquid (including water), or other foreign substances, the machine must be designed and constructed to prevent those substances from reaching the fan system, motor housing, and electrical components. F&SM vacuum motors other than hazardous duty models should not be applied in machines that come in contact with dry chemicals or other volatile materials. Failure to observe these precautions could cause flashing (depending on volatility) or electrical shock which could result in property damage and severe bodily injury, including death in extreme cases. All applications incorporating F&SM motors should be submitted to appropriate organizations or agencies for testing specifically related to the safety of your equipment.

**AMETEK/Floorcare & Specialty Motors**  
**www.ametekfsm.com**

Issued: June, 2010