



DESCRIPTION

- Brushless Motor
- Switch Reluctance (SR) Technology
- Two stage Fan System
- 230 volts, 50/60 Hz
- 5.7" / 145 mm diameter
- Dual 10mm ball bearings
- Peripheral "Acustek" discharge
- All aluminum die cast housings used in motor construction
- Life expectancy: 5 -10 times more than the brush-motor equivalent.

DESIGN APPLICATION

- Equipment operating in environments requiring separation of working air from motor ventilating air
- Designed to handle clean, dry, filtered air only

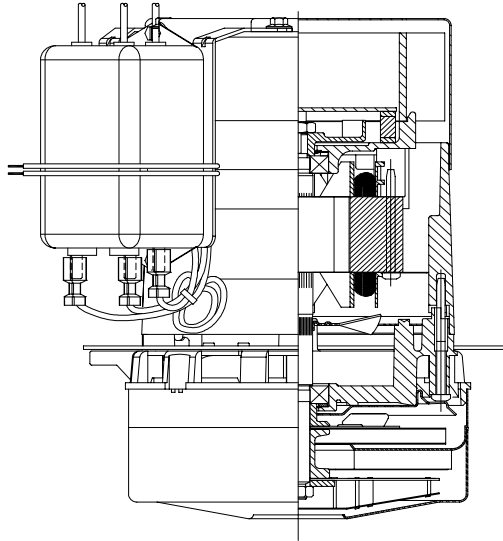

SPECIAL FEATURES

- "Generation II" (DIGITAL) Controller: no external low-voltage control power required. (See "INFIN-A-TEK Application Notes")
- UL component recognized (pending)
- IP Rating: 1.0
- **Speed control capability**
- Tapered fan system
- Thermally protected motor design
- Patented air seal bearing construction (U.S. Patent # 4,088,424)
- Epoxy painted
- Aluminum fan end bracket designed to dampen vibration and improve durability
- **Same as 121102-13, except with EMI Filter**

Please refer to INFIN-A-TEK Application Notes for details on the operation and wiring of this switched-reluctance motor.

TYPICAL MOTOR PERFORMANCE.*

(At 230 volts, AC, test data is corrected to standard conditions of 29.92 Hg, 68° F.)

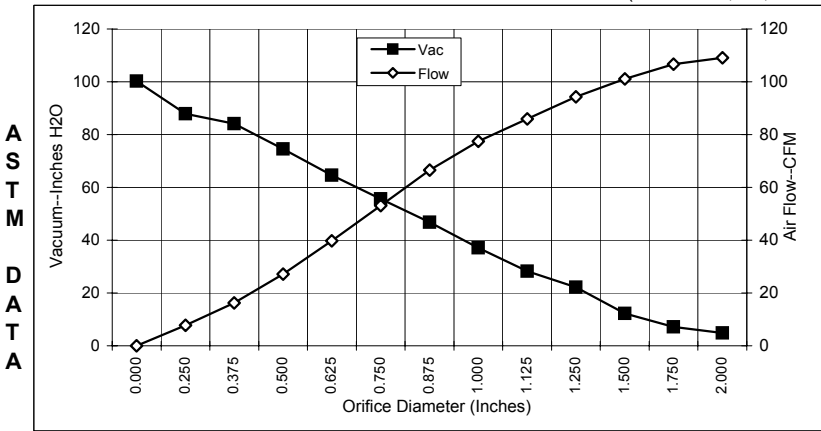

Orifice (Inches)	Amps	Watts (In)	RPM	Vac (In.H ₂ O)	Flow (CFM)	Air Watts
2.000	5.6	1213	20400	4.9	109.1	56
1.750	5.6	1219	20400	7.2	106.7	90
1.500	6.1	1297	20400	12.3	101.1	146
1.250	6.1	1301	20400	22.2	94.3	246
1.125	5.9	1268	19800	28.2	85.9	285
1.000	5.9	1269	19800	37.1	77.5	338
0.875	5.9	1257	19800	46.8	66.6	366
0.750	5.8	1245	19800	55.6	53.1	347
0.625	5.2	1128	21000	64.6	39.7	301
0.500	5.1	1102	21600	74.6	27.2	238
0.375	5.1	989	22800	84.1	16.3	161
0.250	4.3	906	23400	87.9	7.7	80
0.000	3.9	827	24600	100.3	0.0	0

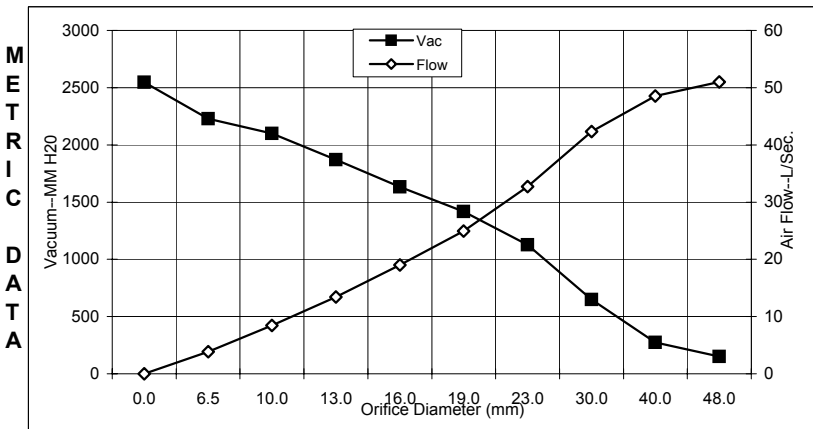

Orifice (mm)	Amps	Watts (In)	RPM	Vac (mm H ₂ O)	Flow (L/Sec)	Air Watts
48.0	5.6	1216	20400	150	51.0	71
40.0	6.0	1274	20400	274	48.5	129
30.0	6.0	1283	20070	648	42.3	267
23.0	5.9	1260	19800	1127	32.7	359
19.0	5.8	1243	19824	1417	24.9	346
16.0	5.2	1133	20952	1632	19.0	303
13.0	5.1	1105	21540	1869	13.4	244
10.0	5.1	1006	22620	2100	8.5	173
6.5	4.3	910	23370	2228	3.8	84
0.0	3.9	827	24600	2548	0.0	0

Note: Metric performance data is calculated from the ASTM data above.

* PERFORMANCE DATA IS PRELIMINARY. PRODUCTION SPECIFICATIONS HAVE NOT YET BEEN SET.

Test Specs:	Minimum Sealed Vacuum: TBA	ORIFICE: TBA	Minimum Vacuum: TBA	Maximum Watts: TBA
--------------------	-----------------------------------	---------------------	----------------------------	---------------------------



DIMENSIONS

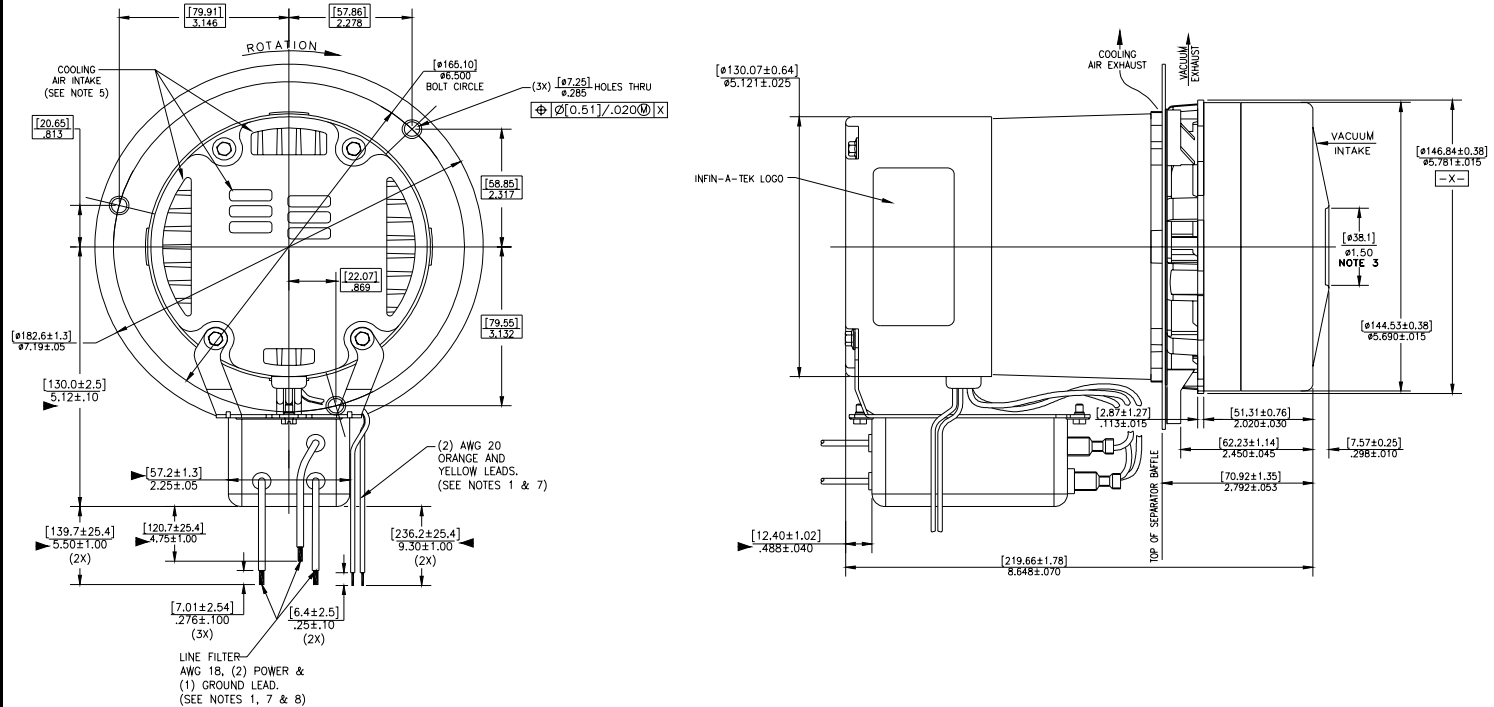

NOTES:

1. Leads: 18ga, stranded power leads; one black and one white, ground lead green with yellow stripe.
Leads: 22ga, control leads: one red, one blue (or orange) and one yellow.
2. Motor Identification: Manufacturer's name, model number, voltage, frequency, inspection code, date of manufacture, agency recognition code, plant code, "Thermally Protected L 16.0A", "Made in the USA" and the following information: "Manufactured under patent nos: US5789893, TW81933, SG38957, ZA96/2766, US5760519, EP0702448B1, ZA95/7123 under license from Switched Reluctance Drive Ltd. Other U.S. and foreign patents pending, copyright code 1998, all rights reserved."
3. Mounting must not restrict this diameter.
4. **Allow (0.0026 Sq M) / 4.8" Sq In. (min) for cooling air intake and exhaust.**
5. Cooling air intake must be separated from cooling air exhaust.
6. Cooling air exhaust must be separated from vacuum exhaust.
7. Observe NEC wiring convention (black-line and white neutral) to insure proper placement of control module fuse in the circuit.
See wiring options 1 thru 4 of "INFIN-A-TEK Application Notes" for implementing the "control" feature (red, blue (or orange) & yellow leads).
8. The INFIN-A-TEK blower utilizes a switched reluctance (SR) brushless motor, which is commutated electronically. Similar to a brush type series universal motor, this INFIN-A-TEK (SR) blower operates on AC voltage. The INFIN-A-TEK (SR) blower features an integral electronic control module that rectifies the "AC line voltage" to obtain the DC voltage required to power the motor. All switched reluctance motors are thermally protected using an auto-reset device. Do not ground test with filter in line.

IMPORTANT NOTE:

Pictorial and dimensional data are subject to change without notice. Contact factory for current revision levels.

WARNING -

When using AMETEK/Lamb Electric bypass motors in machines that come in contact with foam, liquid (including water) or other foreign substances, the machine must be designed and constructed to prevent those substances from reaching the fan system, motor housing and electrical components. Lamb vacuum motors other than hazardous duty models should not be applied in machines that come in contact with dry chemicals or other volatile materials. Failure to observe these precautions could cause flashing (depending on volatility) or electrical shock which could result in property damage and severe bodily injury, including death in extreme cases. All applications incorporating Lamb motors should be submitted to appropriate organizations or agencies for testing specifically related to the safety of your equipment.