



AMETEK
LAMB ELECTRIC

Product Bulletin

Model: 119914-07

DESCRIPTION

- Double stage
- 120 volts
- 5.7" / 145 mm diameter
- Dual ball bearings
- Single speed
- Tangential bypass discharge
- Plastic fan end bracket
- Plastic commutator bracket

DESIGN APPLICATION

- Equipment operating in environments requiring separation of working air from motor ventilating air
- Designed to handle clean, dry, filtered air only

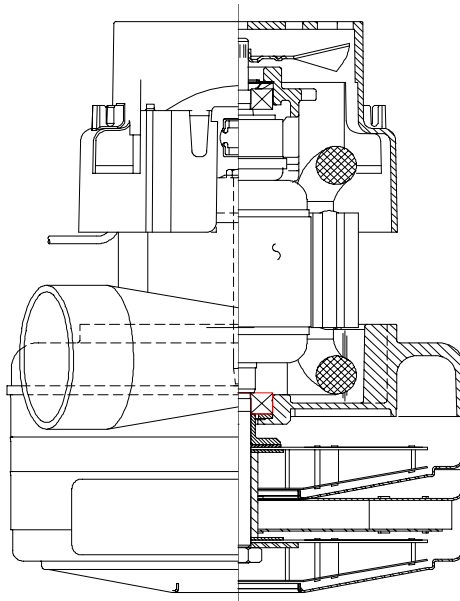

SPECIAL FEATURES

- Suitable for 120 volt AC operation, 50/60 Hz
- UL recognized, category PRGY2 (E47185)
- Provision for grounding
- Skeleton frame design
- Dual Tapered fan system
- The Lamb vacuum motor line offers a wide range of performance levels to meet design needs



TYPICAL MOTOR PERFORMANCE.*

(At 120 volts, 60Hz, test data is corrected to standard conditions of 29.92 Hg, 68° F.)

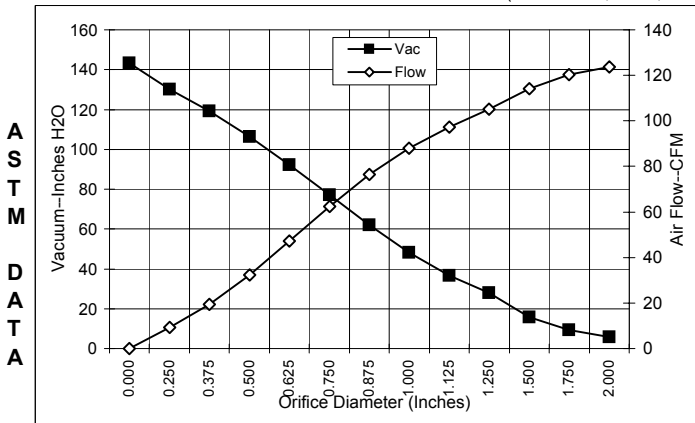

Orifice (Inches)	Amps	Watts (In)	RPM	Vac (In.H ₂ O)	Flow (CFM)	Air Watts
2.000	15.5	1790	24495	5.7	123.7	82
1.750	15.5	1793	24495	9.2	120.2	131
1.500	15.4	1792	24450	15.8	114.2	212
1.250	15.5	1795	24425	27.8	105.2	344
1.125	15.4	1784	24520	36.6	97.4	419
1.000	15.2	1760	24790	48.1	87.9	498
0.875	14.9	1719	25095	62.0	76.4	557
0.750	14.3	1657	25625	77.1	62.4	566
0.625	13.5	1565	26275	92.1	47.2	512
0.500	12.3	1436	27455	106.3	32.4	405
0.375	11.1	1297	28860	119.3	19.3	270
0.250	10.0	1168	30495	130.1	9.2	141
0.000	9.1	1067	31765	143.3	0.0	0

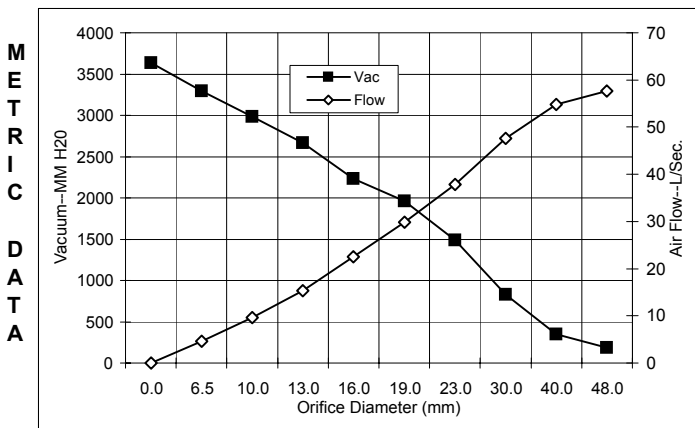

Orifice (mm)	Amps	Watts (In)	RPM	Vac (mm H ₂ O)	Flow (L/Sec)	Air Watts
48.0	15.5	1791	24495	184	57.7	104
40.0	15.5	1792	24464	352	54.8	188
30.0	15.5	1788	24477	829	47.6	385
23.0	15.0	1729	25019	1486	37.8	515
19.0	14.3	1655	25638	1965	29.8	528
16.0	13.5	1569	26249	2230	22.5	470
13.0	12.4	1449	27337	2665	15.3	416
10.0	11.3	1318	28649	2981	9.6	291
6.5	10.0	1174	30413	3292	4.6	148
0.0	9.1	1067	31765	3639	0.0	0

Note: Metric performance data is calculated from the ASTM data above.

* Data represents performance of a typical motor sampled from a large production quantity. Individual motor data may vary to normal manufacturing variations.

Test Specs:	120 volt	Minimum Sealed Vacuum: 76	134.0	ORIFICE: 7/8"	Minimum Vacuum: 58.0	Maximum Watts: 1770
--------------------	----------	----------------------------------	-------	----------------------	-----------------------------	----------------------------

DIMENSIONS

NOTES:

1. POWER LEADS: 18GA STRANDED. LEADS CAN BE ANY COLOR EXCEPT GREEN OR GREEN WITH YELLOW STRIPE. GROUND LEAD: 18GA STRANDED, GREEN OR GREEN WITH YELLOW STRIPE.
2. MOTOR IDENTIFICATION: MANUFACTURER'S NAME, MODEL NUMBER, VOLTAGE, FREQUENCY, INSPECTOR'S CODE WITH "FF" SUFFIX, DATE OF MANUFACTURE, AGENCY RECOGNITION CODE, PLANT LOCATION CODE, PATENT INFORMATION "ONE OR MORE OF THE FOLLOWING PATENTS APPLY TO THIS MOTOR: 5482378; 5736806; 4669952; 4684835; 6561772". AND COUNTRY OF ORIGIN.
3. ALLOW (.0016 SQ M)/2.5 SQ IN. MIN. FOR COOLING AIR INTAKE.
4. COOLING AIR INTAKE MUST BE SEPARATED FROM COOLING AIR EXHAUST.
5. VACUUM EXHAUST MUST BE SEPARATED FROM COOLING AIR EXHAUST.
6. MOUNTING MUST NOT RESTRICT THIS DIAMETER.

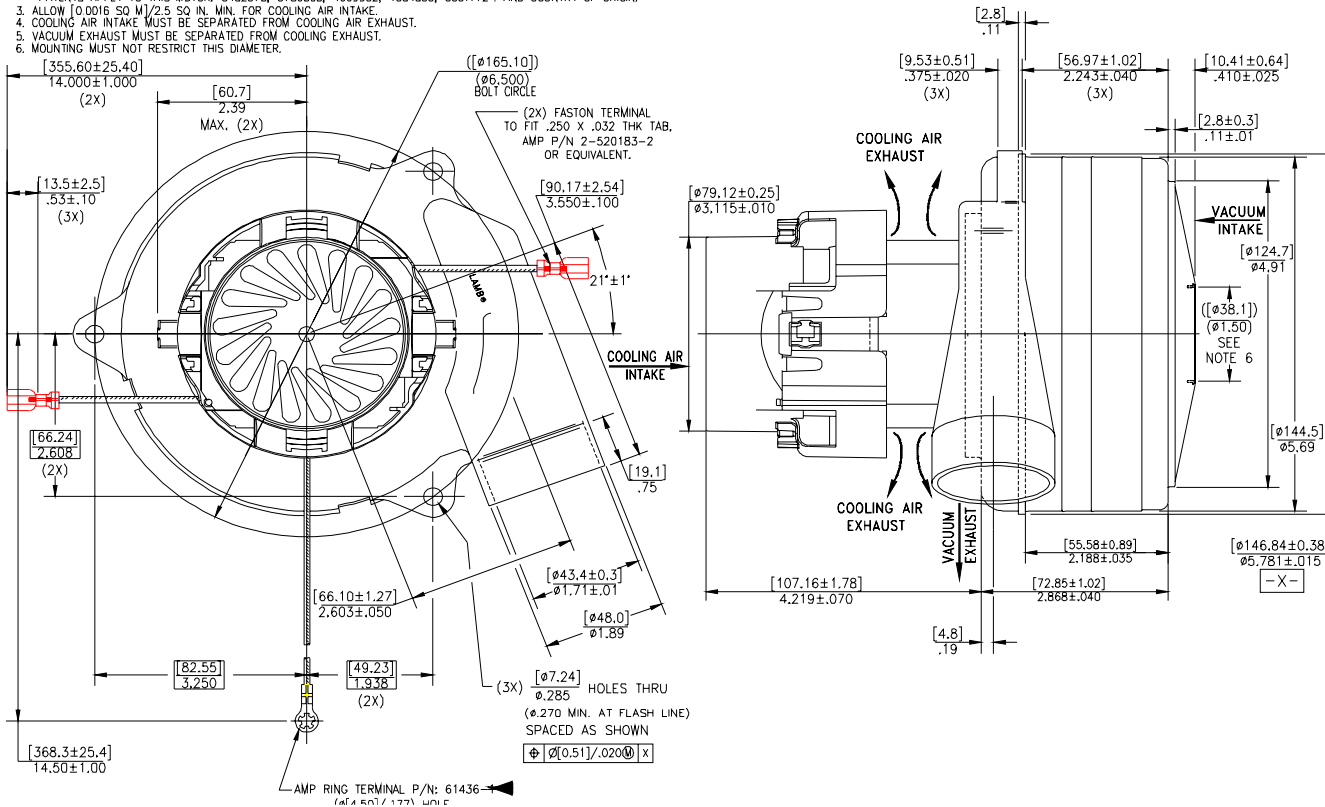

IMPORTANT NOTE: Pictorial and dimensional data are subject to change without notice. Contact factory for current revision levels.

WARNING - When using AMETEK/Lamb Electric bypass motors in machines that come in contact with foam, liquid (including water) of other foreign substances, the machine must be designed and constructed to prevent those substances from reaching the fan system, motor housing and electrical components. Lamb vacuum motors other than hazardous duty models should not be applied in machines that come in contact with dry chemicals or other volatile materials. Failure to observe these precautions could cause flashing (depending on volatility) or electrical shock which could result in property damage and severe bodily injury, including death in extreme cases. All applications incorporating Lamb motors should be submitted to appropriate organizations or agencies for testing specifically related to the safety of your equipment.

AMETEK/Lamb Electric Division
 627 Lake Street
 Kent, Ohio 44240
 U.S.A.
 Tel: (330) 673-3786 Fax: (330) 677-3812
 www.lambelectric.com