



LAMB ELECTRIC



Model: 119903-00

SPECIAL FEATURES

- Suitable for 240 volt AC operation, 50 or 60 Hz
- UL recognized, category PRGY2 (E47185)
- Provision for grounding
- Skeleton frame design
- Tapered fan system
- High air flow fan system
- Theraml Device
- Choke Coils

- The Lamb vacuum motor line offers a wide range of performance levels to meet design needs

DESCRIPTION

- Two stage
- 240volts
- 5.7" / 145 mm diameter
- Double Ball bearings
- Single speed
- Thru-Flow discharge
- Aluminum fan end bracket
- Aluminum commutator bracket

DESIGN APPLICATION

- Equipment operating in environments requiring separation of working air from motor ventilating air
- Designed to handle clean, dry, filtered air only

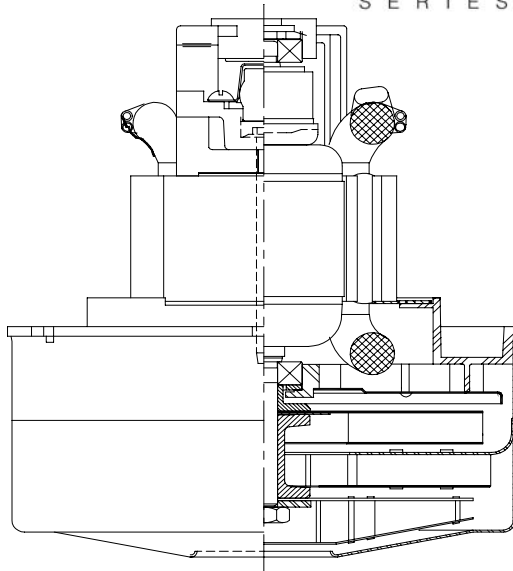

PEAK AIRWATTS
502
Calculated in accordance with ASTM F2105

TYPICAL MOTOR PERFORMANCE.*

(At 240 volts AC, test data is corrected to standard conditions of 29.92 Hg, 68° F.)

ASTM DATA

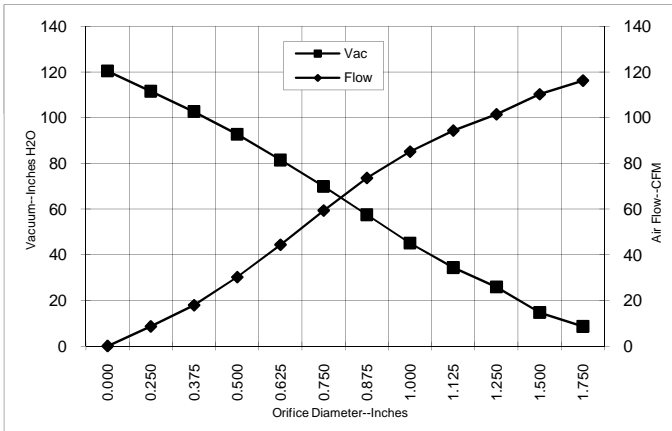

Orifice (Inches)	Amps	Watts (In)	RPM	Vac (In.H ₂ O)	Flow (CFM)	Air Watts
2.000	6.1	1404	22060	5.3	119.1	73
1.750	6.2	1405	22060	8.6	116.3	118
1.500	6.2	1419	21850	14.7	110.3	191
1.250	6.2	1418	21850	25.9	101.5	309
1.125	6.3	1429	21850	34.4	94.4	381
1.000	6.2	1409	21850	45.1	85.2	452
0.875	6.0	1370	22250	57.5	73.6	497
0.750	5.7	1307	22840	69.9	59.4	488
0.625	5.3	1220	23630	81.5	44.4	425
0.500	4.8	1114	24600	92.8	30.2	329
0.375	4.4	1009	25990	102.7	17.9	216
0.250	4.4	909	27160	111.6	8.6	113
0.000	3.9	841	28340	120.5	0.0	0

METRIC DATA

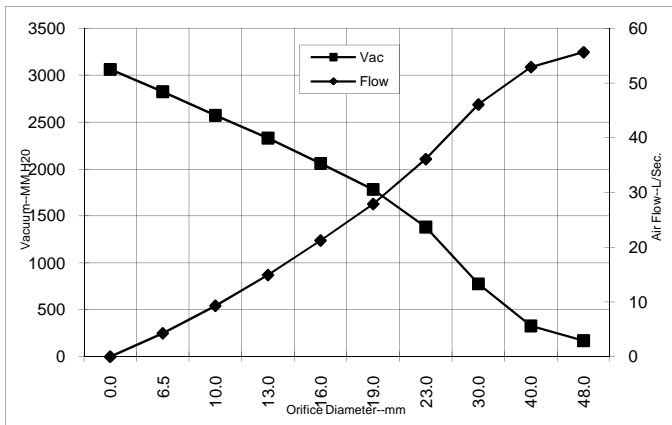

Orifice (mm)	Amps	Watts (In)	RPM	Vac (mm H ₂ O)	Flow (L/Sec)	Air Watts
48.0	6.1	1404	22060	171	55.6	93
40.0	6.2	1415	21913	327	52.9	169
30.0	6.3	1424	21850	777	46.1	349
23.0	6.1	1380	22150	1382	36.1	486
19.0	5.7	1305	22856	1781	27.9	487
16.0	5.3	1223	23598	2058	21.2	428
13.0	4.9	1125	24503	2328	14.9	339
10.0	4.4	1025	25782	2571	9.3	233
6.5	4.4	914	27102	2823	4.3	118
0.0	3.9	841	28340	3061	0.0	0

Note: Metric performance data is calculated from the ASTM data above.

* Data represents performance of a typical motor sampled from a large production quantity. Individual motor data may vary due to normal manufacturing variations.

Test Specs: 2400 volts	Minimum Sealed Vacuum: TBD	ORIFICE: 7/8"	Minimum Vacuum: TBD	Maximum Watts: TBD
-------------------------------	-----------------------------------	----------------------	----------------------------	---------------------------

DIMENSIONS

NOTES:

1. LEADS: 18GA STRANDED.
2. GROUNDING OR EARTHING PROVISIONS: USE HOLES AS INDICATED FOR GROUNDING OR EARTHING. REFER TO APPROPRIATE LISTING OR REGULATORY AGENCY FOR PROPER METHOD OF GROUNDING OR EARTHING.
3. MOTOR IDENTIFICATION: MANUFACTURER'S NAME, MODEL NUMBER, VOLTAGE, FREQUENCY, INSPECTOR'S CODE, DATE OF MANUFACTURE, AGENCY RECOGNITION CODE, PLANT LOCATION CODE AND COUNTRY OF ORIGIN.
4. MOUNTING MUST NOT RESTRICT THIS DIAMETER.

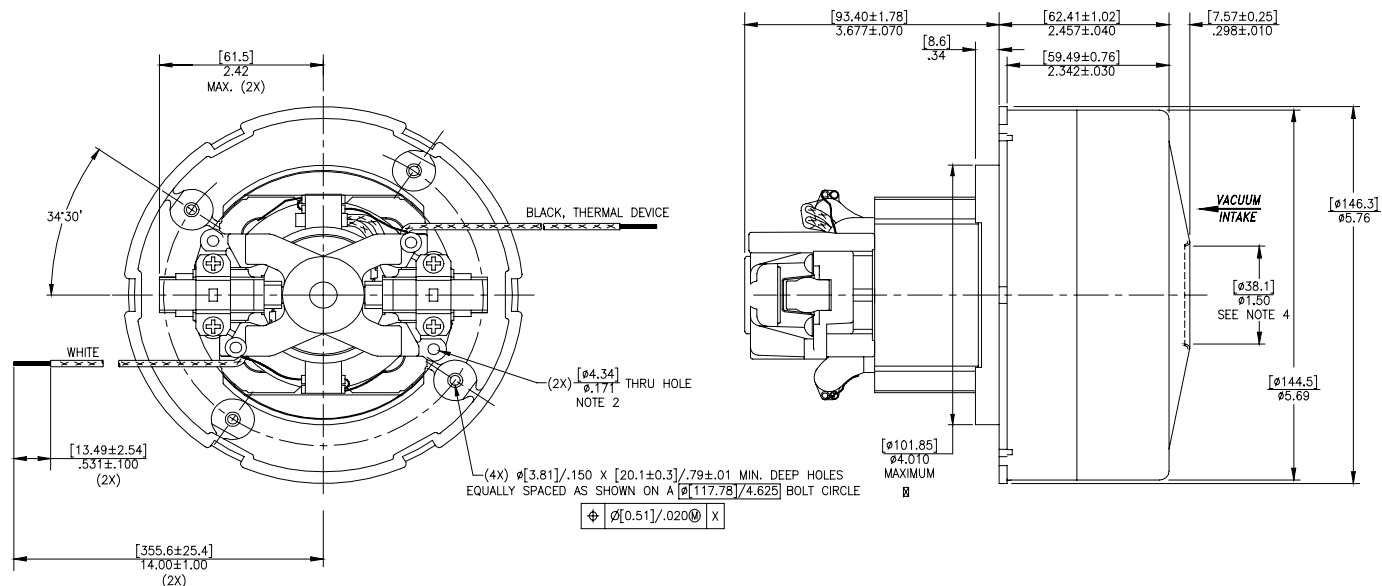

IMPORTANT NOTE: Pictorial and dimensional data are subject to change without notice. Contact factory for current revision levels.

WARNING - AMETEK Lamb Electric thru-flow vacuum motors must never be used in applications in which wet or moist conditions are involved, where dry chemicals or other volatile materials are present, or where airflow may be restricted or blocked. Such motors are designed to permit the vacuumed air to pass over the electrical winding to cool it. Thus any foam, liquid (including water), dry chemical, or other foreign substance coming in contact with electrical conductors could cause combustion (depending on volatility) or electrical shock. Failure to observe these precautions could result in property damage and severe personal injury, including death in extreme cases. All applications incorporating Lamb Electric motors should be submitted to Underwriters Laboratories Inc. or other appropriate organizations or agencies for testing specifically related to the safety of your equipment.

AMETEK Lamb Electric
 627 Lake Street
 Kent, Ohio 44240
 U.S.A.
 Tel: (330) 673-3786 Fax: (330) 677-3812
 www.lambelectric.com