



**AMETEK**  
**LAMB ELECTRIC**

**Product Bulletin**

**Model: 116379-00**

**DESCRIPTION**

- Two stage
- 240 volts
- 4.3" / 106 mm diameter
- Dual ball bearings
- Single speed
- Thru-flow discharge
- Aluminum fan end bracket
- Aluminum commutator bracket

**DESIGN APPLICATION**

- Equipment operating in environments not requiring separation of working air from motor ventilating air
- Designed to handle clean, dry, filtered air only

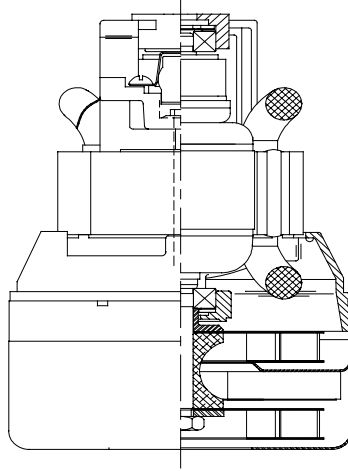

**SPECIAL FEATURES**

- Suitable for 240 volt AC operation, 50/60 Hz
- UL recognized, category PRGY2 (E47185)
- Provision for grounding
- The Lamb vacuum motor line offers a wide range of performance levels to meet design needs

**TYPICAL MOTOR PERFORMANCE.\***

(At 240 volts, 60Hz, test data is corrected to standard conditions of 29.92 Hg, 68° F.)

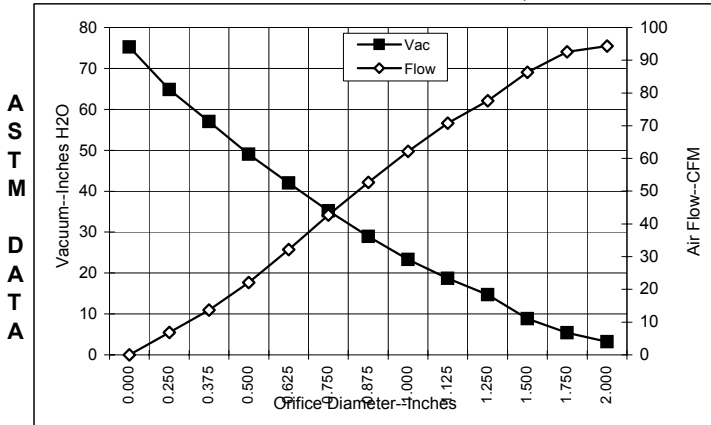

Orifice (Inches)	Amps	Watts (In)	RPM	Vac (In.H <sub>2</sub> O)	Flow (CFM)	Air Watts
2.000	3.8	872	21175	3.2	94.3	36
1.750	3.8	872	21170	5.4	92.6	58
1.500	3.8	870	21210	8.8	86.3	90
1.250	3.8	860	21345	14.7	77.6	135
1.125	3.7	848	21530	18.7	70.8	156
1.000	3.6	826	21865	23.3	62.2	171
0.875	3.5	800	22290	28.9	52.7	179
0.750	3.3	758	23015	35.2	42.7	177
0.625	3.0	704	24050	42.0	32.2	159
0.500	2.8	648	25305	49.0	22.1	127
0.375	2.6	595	26765	57.0	13.7	92
0.250	2.4	553	27900	64.8	6.8	52
0.000	2.1	515	29210	75.2	0.0	0

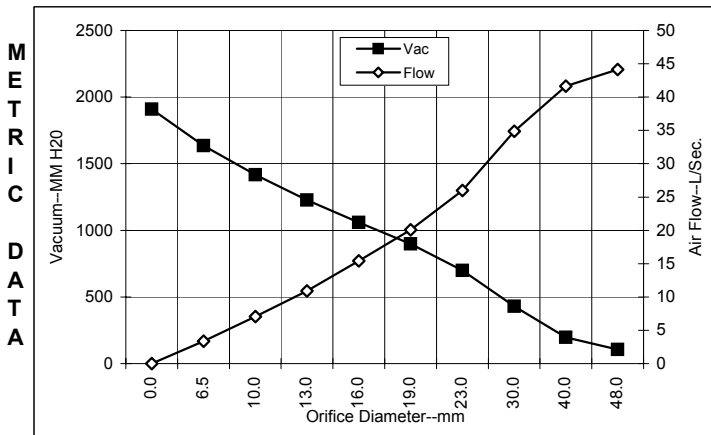

Orifice (mm)	Amps	Watts (In)	RPM	Vac (mm H <sub>2</sub> O)	Flow (L/Sec)	Air Watts
48.0	3.8	872	21173	106	44.2	46
40.0	3.8	871	21198	198	41.6	80
30.0	3.7	853	21447	429	34.9	147
23.0	3.5	807	22184	699	26.0	177
19.0	3.3	757	23036	898	20.1	177
16.0	3.0	706	24009	1060	15.4	160
13.0	2.8	654	25180	1227	10.9	130
10.0	2.6	603	26546	1417	7.1	97
6.5	2.4	555	27843	1636	3.4	54
0.0	2.1	515	29210	1910	0.0	0

Note: Metric performance data is calculated from the ASTM data above.

\* Data represents performance of a typical motor sampled from a large production quantity. Individual motor data may vary to normal manufacturing variations.

Test Specs: 240 volts	Minimum Sealed Vacuum: 62.0"	ORIFICE: 13 mm	Minimum Vacuum: 43.5"	Maximum Watts: 900
-----------------------	------------------------------	----------------	-----------------------	--------------------

**DIMENSIONS**

NOTES:

1. LEADS: 18 GA. STRANDED. LEADS CAN BE ANY COLOR EXCEPT GREEN OR GREEN WITH YELLOW STRIPE.
2. GROUNDING OR EARTHING PROVISION: USE HOLES AS INDICATED FOR GROUNDING OR EARTHING. REFER TO APPROPRIATE LISTING OR REGULATORY AGENCY FOR PROPER METHOD OF GROUNDING OR EARTHING.
3. MOTOR IDENTIFICATION: MANUFACTURER'S NAME, MODEL NUMBER, VOLTAGE, FREQUENCY, INSPECTORS CODE, DATE OF MANUFACTURE, AGENCY RECOGNITION CODE, PLANT LOCATION CODE AND MADE IN USA.

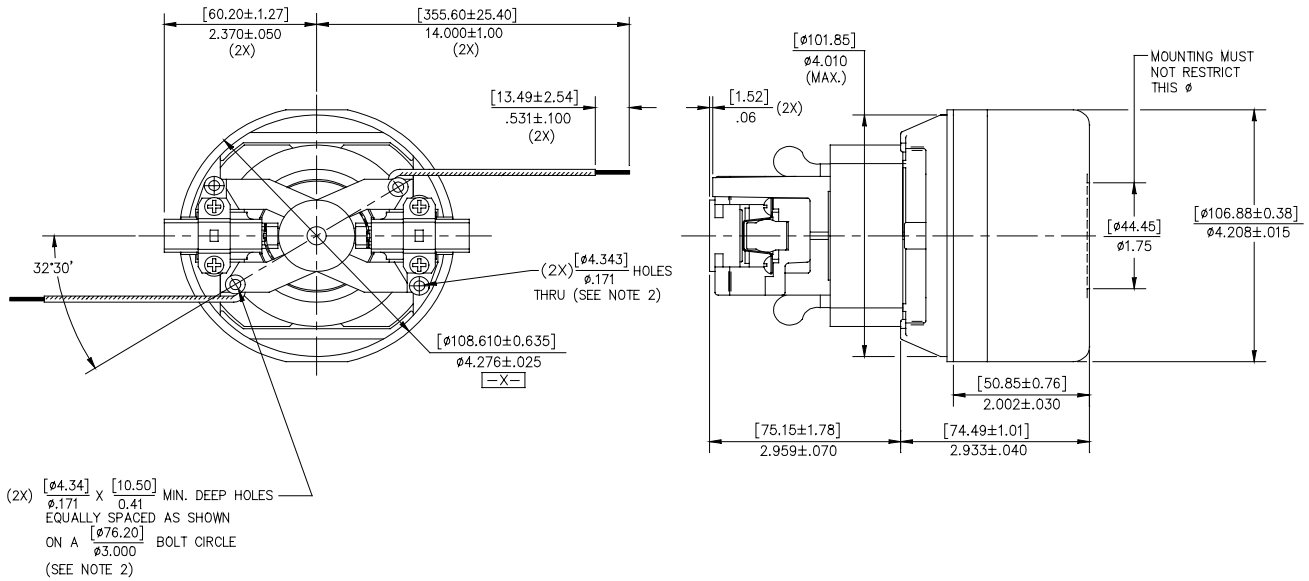

**IMPORTANT NOTE:** Pictorial and dimensional data are subject to change without notice. Contact factory for current revision levels.

**WARNING** - Ametek/Lamb Electric thru-flow vacuum motors must never be used in applications in which wet or moist conditions are involved, where dry chemicals or other volatile materials are present or where airflow may be restricted or blocked. Such motors are designed to permit the vacuumed air to pass over the electrical winding to cool it. Thus any foam, liquid (including water), dry chemical or other foreign substance will come in contact with electrical conductors which could cause combustion (depending on volatility) or electrical shock. Failure to observe these precautions could result in property damage and severe personal injury, including death in extreme cases. All applications incorporating Lamb motors should be submitted to Underwriters Laboratories Inc. or other appropriate organizations or agencies for testing specifically related to the safety of your equipment.

**AMETEK/Lamb Electric Division**  
 627 Lake Street  
 Kent, Ohio 44240  
 U.S.A.  
 Tel: (330) 673-3451  
 Fax: (330) 673-8994

**Ametek GmbH**  
 P. O. Box 1251  
 D-71667 Marbach  
 Germany  
 Phone: + 49-714-484-9512  
 Fax: + 49-714-484-9513

**AMETEK/Singapore Private Limited**  
 10 Ang Mo Kio Street 65  
 # 05-12 Techpoint  
 Singapore 2056  
 Tel: + 65-484-2388  
 Fax: + 65-481-6588